

# DIGITALES ARCHIV

ZBW – Leibniz-Informationszentrum Wirtschaft  
ZBW – Leibniz Information Centre for Economics

Rahayu, Hevearita Gunaryanti; Warsono, Hardi; Kurniati, Rina et al.

## Article

# The effect of green intellectual capital on green competitive advantage in sustainable city management

## Provided in Cooperation with:

International Journal of Energy Economics and Policy (IJEPP)

*Reference:* Rahayu, Hevearita Gunaryanti/Warsono, Hardi et. al. (2023). The effect of green intellectual capital on green competitive advantage in sustainable city management. In: International Journal of Energy Economics and Policy 13 (3), S. 532 - 537.  
<https://www.econjournals.com/index.php/ijeep/article/download/14434/7334/33330>.  
doi:10.32479/ijeep.14434.

This Version is available at:

<http://hdl.handle.net/11159/631239>

## Kontakt/Contact

ZBW – Leibniz-Informationszentrum Wirtschaft/Leibniz Information Centre for Economics  
Düsternbrooker Weg 120  
24105 Kiel (Germany)  
E-Mail: [rights\[at\]zbw.eu](mailto:rights[at]zbw.eu)  
<https://www.zbw.eu/econis-archiv/>

## Standard-Nutzungsbedingungen:

Dieses Dokument darf zu eigenen wissenschaftlichen Zwecken und zum Privatgebrauch gespeichert und kopiert werden. Sie dürfen dieses Dokument nicht für öffentliche oder kommerzielle Zwecke vervielfältigen, öffentlich ausstellen, aufführen, vertreiben oder anderweitig nutzen. Sofern für das Dokument eine Open-Content-Lizenz verwendet wurde, so gelten abweichend von diesen Nutzungsbedingungen die in der Lizenz gewährten Nutzungsrechte.

<https://zbw.eu/econis-archiv/termsfuse>

## Terms of use:

*This document may be saved and copied for your personal and scholarly purposes. You are not to copy it for public or commercial purposes, to exhibit the document in public, to perform, distribute or otherwise use the document in public. If the document is made available under a Creative Commons Licence you may exercise further usage rights as specified in the licence.*



# The Effect of Green Intellectual Capital on Green Competitive Advantage in Sustainable City Management

**Hevearita Gunaryanti Rahayu\***, **Hardi Warsono**, **Rina Kurniati**, **Hartuti Purnaweni**

Faculty of Social and Political Sciences, Universitas Diponegoro, Indonesia. \*Email: [hgrahayu.undip@gmail.com](mailto:hgrahayu.undip@gmail.com)

**Received:** 10 February 2023

**Accepted:** 07 May 2023

**DOI:** <https://doi.org/10.32479/ijeep.14434>

## ABSTRACT

Resource-based view (RBV) is a valuable theoretical foundation in analyzing organizational strategic resources to achieve Green Competitive Advantage in green city management. The purpose of this study is to analyze the strategic resources of the Semarang municipal government and this public sector capability in achieving a green competitive advantage in the management of green city. The application of the green city concept aims to create a more sustainable and environmentally friendly environment, by optimizing the use of renewable energy and reducing emissions. The use of this renewable energy can also provide a more stable and secure energy source because it does not depend on the irregular supply of fossil fuels and is vulnerable to price fluctuations. The method used is by quantitative techniques through Structural Equation Modeling (SEM) with a number of 116 respondents in Semarang City municipal government was taken as the sample through purposive sampling technique. The findings through quantitative analysis shows that green intellectual capital, eco-innovation and transformational leadership factors have a significant effect on Green Competitive Advantage in the context of green city management. As a suggestion, it is advisable to enhance the capacity for sharing a common vision, facilitating communication among parties involved, implementing sustainable management practices, nurturing human resources, and employing a collaborative governance framework for the purpose of building a green city in Semarang, Indonesia.

**Keywords:** Green Intellectual Capital, Eco-innovation, Transformational Leadership, Green Competitive Advantage, Green City, Collaborative Governance

**JEL Classifications:** Q15; Q48; Q56

## 1. INTRODUCTION

Environmental management of green cities is a development challenge in various parts of the world, especially for developing countries (Hegazy et al., 2017). Environmental management of green cities aims to balance economic development with sustainability and environmental protection, and to create livable and healthy environments for citizens (Garau and Pavan, 2018). In addition, the application of the green city concept aims to create a more sustainable and environmentally friendly environment, by optimizing the use of renewable energy and reducing greenhouse gas emissions. The challenge of environmental management in green cities is to achieve a balance between economic growth and environmental protection. Urbanization and industrialization

have led to increased pollution and depletion of natural resources in many cities around the world (Ray and Ray, 2011; Zahoor et al., 2022). Green city environmental management requires a comprehensive and integrated approach that includes the use of renewable energy to achieve environmental sustainability goals. Then, environmental management of green cities must also pay attention to the entire energy cycle, from production to use and recycling. Reducing the use of fossil energy and the use of renewable energy must be combined with waste reduction and wastewater management to create a sustainable and environmentally friendly energy cycle. Many cities in Europe have implemented sustainable urban management policies aimed at mitigating numerous environmental, social, and economic challenges as the consequences of rapid urbanization

and industrialization (Nijkamp and Perrels, 2014). Simpson and Zimmermann (2012) highlighted that the success of sustainable green city management is influenced by stakeholder collaboration, environmental management, diversification of funding sources, innovative solutions, and spatial planning that is pro-environment.

This all needs transformational leadership as the basis. The initiatives of green city management are to promote renewable energy sources, sustainable transportation options, green infrastructure, and green building technologies. These policies have led to significant reductions in carbon emissions, improved urban livelihoods, and promoted biodiversity. Transformational leadership is a leadership model that focuses on inspiring and motivating followers to achieve a common goal. According to Bass and Avolio (1993), transformational leaders articulate a vision and inspire followers by providing a sense of purpose and direction. Transformational leaders also foster individual creativity, challenge followers to think critically, and provide personalized support and recognition to organizational members. They also encourage members to identify and work towards achieving their own individual goals.

In this case, the Semarang City Government has made various efforts in managing a green city by implementing renewable energy, among others, is focused on building infrastructure and environmental landscapes. Semarang city's present approach to promoting a green city is connected with a fresh direction in development policies. This innovation was carried out on the role of various stakeholders such as the central government which assisted in green funding, stakeholder engagement and environmental orientation. By looking at various interrelated factors in the management of green city in public sector organization context, this study is to analyze the strategic resources and their influences in achieving a green competitive advantage. This study explored green city management by taking Semarang City as the research object. In this contest, the issue and public policy of the management of green city is a complex issue in which there are various interests from both an environmental and economic perspective. The collaboration among various parties with their respective capabilities was carried out to foster eco-innovation capability and green competitive advantage as complex environmental issues in which there are various interests from both an environmental and economic perspective. Theoretical foundations used for this research were Resource Based View (RBV) combined with Collaborative Governance (CG) and Knowledge Management (KM) in public sector organizations (PSOs). Resource-based view (RBV) in terms of organizational strategic resources has been adopted in public sector organizations (PSOs) as valuable theoretical foundation in analyzing knowledge management (KM) to achieve Green Competitive Advantage in green city management (Abbas and Sağsan, 2019; Chopra et al., 2021). Moreover, Resource Based View (RBV) have been also explored to examine collaborative governance in sustainable engagement (Zheng et al., 2013; Barrutia and Echebarria, 2015). More specifically, the current research was to examine the empirical evidence of the effect of green intellectual capital on Green Competitive Advantage by using mediating variable of Eco-innovation management and Transformational Leadership.

## 2. THEORETICAL FRAMEWORK AND HYPOTHESIS

Innovation in green city management arises when there is intensive interaction and communication between the public sector and its environment. Interaction and communication with the external environment are the relationship between public agencies, general public and its stakeholders. Interaction with stakeholders in sustainable green practices contributes to eco-innovation (Garcés-Ayerbe et al, 2019). According to Avolio et al. (1999), transformational leaders can inspire stakeholders to recognize the benefits of sustainable living, engage in collective action, and promote sustainable practices that enhance resource management and conservation, and accelerating the transition to the use of renewable energy. Adopting sustainable practices such as saving energy, using eco-friendly transportation, and reducing waste can help reduce the negative impact on the environment and limited natural resources. In addition, by engaging in collective action, you can also strengthen the sustainable movement and influence policies that support renewable energy and sustainable environmental management. Organization can leverage strong relational capabilities to improve coordination and collaboration, thereby creating greater shared value than could be achieved individually, including in green city management. Transformational leadership capabilities can also help organization to obtain valuable resources and information from stakeholders, which can be used to develop new services or improve processes in delivering green competitive advantage (Chen and Chang, 2013). In this case, transformational leadership capabilities can help organization achieve green competitive advantage by utilizing intellectual resources within organization. Xi et al. (2023) have also highlighted the importance of green intellectual capital in promoting sustainable practices and transformational leadership. Jia et al. (2018) found that environmental knowledge and skills positively influence transformational leadership, while environmental values have a direct positive effect on employee engagement in sustainable practices.

Yong et al. (2019), Ullah et al. (2022) found that green intellectual capital positively affects eco-innovation capability in the manufacturing industry. Qu et al. (2022) found that knowledge of green technologies, the willingness to invest in environmental R&D, and pro-environment attitudes among employees were significant predictors of eco-innovation capability. Chen et al. (2017) found that green intellectual capital positively influences eco-innovation capability, and that employee knowledge, green practices, and environmental management systems were important factors. Xi et al. (2022) found that green intellectual capital positively influences transformational leadership, and that transformational leadership positively influences environmental performance. Yusoff et al. (2019) suggest that organizations with higher levels of green intellectual capital are better equipped to implement environmentally sustainable practices, and that transformational leaders can help to facilitate the adoption of these practices by inspiring and guiding their employees.

Niazi et al. (2023) found that transformational leadership positively influenced green innovation and environmental performance.

Sun et al. (2022) found that transformational leadership positively influenced environmental management practices and environmental performance. Huang et al. (2021) found that transformational leadership positively influenced the adoption of environmentally sustainable practices. Galera-Quiles et al. (2021) found that transformational leadership positively influenced the adoption of eco-innovations. Moreover, Teixeira et al. (2016) found that transformational leadership positively influenced the perception of environmental responsibility. Crucke et al. (2022) found that transformational leadership positively influenced the perception of environmental responsibility.

Kuo et al. (2022) examined the relationship between eco-innovation capability and green competitive advantage. Cai and Li (2018) found that eco-innovation capabilities, including technological capabilities, organizational capabilities, and market capabilities, had a significant positive impact on green competitive advantage. In addition, Bag et al. (2022), Yang et al. (2020) found that organizations with higher eco-innovation capabilities were more likely to engage in sustainable practices, such as eco-design, green supply chain management. Kuo et al. (2022) found that eco-innovation capabilities were positively associated with green competitive advantage in terms of cost savings, innovation, and organizational reputation.

- H<sub>1</sub>: Green intellectual capital has a significant influence on Eco-Innovation Capability
- H<sub>2</sub>: Green intellectual capital has a significant influence on Transformational Leadership
- H<sub>3</sub>: Green intellectual capital has a significant effect on Green Competitive Advantage
- H<sub>4</sub>: Transformational Leadership has a significant influence on Green Competitive Advantage
- H<sub>5</sub>: Eco-Innovation Capability has a significant influence on Green Competitive Advantage
- H<sub>6</sub>: Eco-Innovation Capability mediates the relationship between Green intellectual capital with Green Competitive Advantage
- H<sub>7</sub>: Transformational Leadership mediates the relationship between Green intellectual capital and Green Competitive (Figure 1).

### 3. RESEARCH METHOD

This study uses empirical analysis to identify relevant factors in green management as a basis for determining and classifying Resource-Based View (RBV) constructs in green city management by implementing renewable energy in the context of public sector organizations. Quantitative measurement was adopted to empirically

Figure 1: Conceptual Model

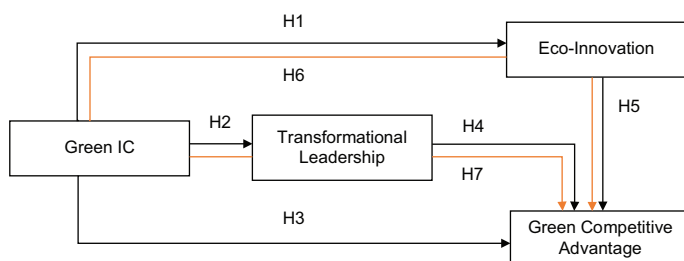

examine the effect of green intellectual capital on Eco-Innovation Capability and Transformational Leadership as mediating variables and on Green Competitive Advantage as dependent variable. The sampling method used for this empirical examination was 116 respondents by using purposive sampling method. The respondents were selected by their knowledge and involvement in the green management and projects. The main informant determined in this study is the Semarang municipal government.

This research took the measuring items of transformational leadership from Bass and Avolio (1993) which include; idealized influence, inspirational motivation, intellectual stimulation, and individualized consideration. The variable of Green intellectual capital was measured by using modified items from Yadiati et al. (2019), including green relational capital, green relational capital, and green human capital, investment in renewable energy and sustainable innovation. Moreover, the variable Eco-innovation was measured by using items adopted from Chen and Hou (2016), including environmental commitment, green collaboration and employee engagement. Lastly, the variable of green competitive advantage was measured by using four items including organizational green reputation, environmental quality, green financing resources and green strategic partnerships.

Data analysis in this study used a qualitative descriptive analytical method with the help of atlas.ti program and by using Structural Equation Modeling (SEM) to analyze empirical evidences. Data collection was conducted by distributing questionnaires to the respondents with 7-point Likert scale. The technique of analysis used was by Structural Equation Modeling (SEM) with AMOS program.

### 4. RESULTS

To increase the possible internal validity of the instrument, this study conducted a pilot study. As shown in Table 1, the results

Table 1: Pilot testing

Variable and indicator	Validity	Matrix component	Cronbach alpha
Green intellectual capital			0.883
Green relational capital	0.835	0.822	
Green relational capital	0.806	0.760	
Green human capital	0.861	0.801	
Investment in renewables	0.793	0.797	
Sustainable innovation	0.834	0.821	
Transformational leadership			0.910
Idealized influence	0.876	0.810	
Inspirational motivation	0.905	0.869	
Intellectual stimulation	0.870	0.828	
Individualized consideration	0.900	0.776	
Eco-innovation capability			0.869
Environmental commitment	0.879	0.725	
Green Collaboration	0.921	0.788	
Stakeholder engagement	0.882	0.799	
Green competitive advantage			0.923
Organizational green reputation	0.921	0.817	
Environmental Quality	0.960	0.827	
Green financing resources	0.907	0.827	
Green strategic partnerships	0.816	0.887	



of the pilot study show that the data is valid and reliable for hypothesis testing. The test results show that the Cronbach's alpha coefficient for all variables is above the cut-off value of 0.6, the validity coefficient is above the cut-off value of 0.203 (df = 30,  $\alpha = 0.05$ ), and the matrix component coefficient is above the cut-off value of 0.5.

The main analysis used from the collected data is based on the structural equation model (SEM). Testing the relationship of latent variables was carried out using AMOS version 24. The results of the SEM analysis in this study can be seen in Figure 2.

The hypothesis testing as shown in Table 2 and Figure 3 reveals some important findings. First, the results of the study reveal that the influence of Green intellectual capital on Eco-Innovation Capability gets an estimate value (0.639), SE (0.154) and CR (4.144) with  $P < 0.000$ . These results prove that hypothesis 1 can be accepted. Second, the results of the analysis show that the influence of Green intellectual capital on Transformational Leadership gets an estimate value (0.642), SE (0.125), CR (5.138) with  $P < 0.000$ . With the results of the analysis obtained, it can also be concluded that the second hypothesis which states that Green intellectual

capital has a significant influence on Transformational Leadership can be accepted. Third, testing the effect of Green intellectual capital on Green Competitive Advantage gets an estimate value (0.393), SE (0.217), CR (1.814) with a  $P = 0.070$ . For the results of the third hypothesis analysis this cannot be accepted because the P-value results obtained are more than 0.050. Fourth, the results of the analysis of the influence of Transformational Leadership on Green Competitive Advantage show an estimated value (0.830), SE (0.158), CR (5.224) with  $P < 0.000$ . Therefore, it can be concluded that the fourth hypothesis can be accepted. Then fifth, testing the results of the analyst on the hypothesis shows the results of the estimated value (0.156), SE (0.119), CR (1.314) with a  $P = 0.189$ . In the fifth hypothesis test which states that Eco-Innovation Capability has a significant effect on Green Competitive Advantage cannot be accepted because the P-value obtained is more than 0.050. The results of hypothesis testing in this study are presented in Table 3.

Then, in this study there is a significant test using mediation to determine the possibility of intervening variables to become mediators. Test the significance test using this mediation using the Sobel test calculator. This test determines the one-sided

Figure 2: Structural equation model

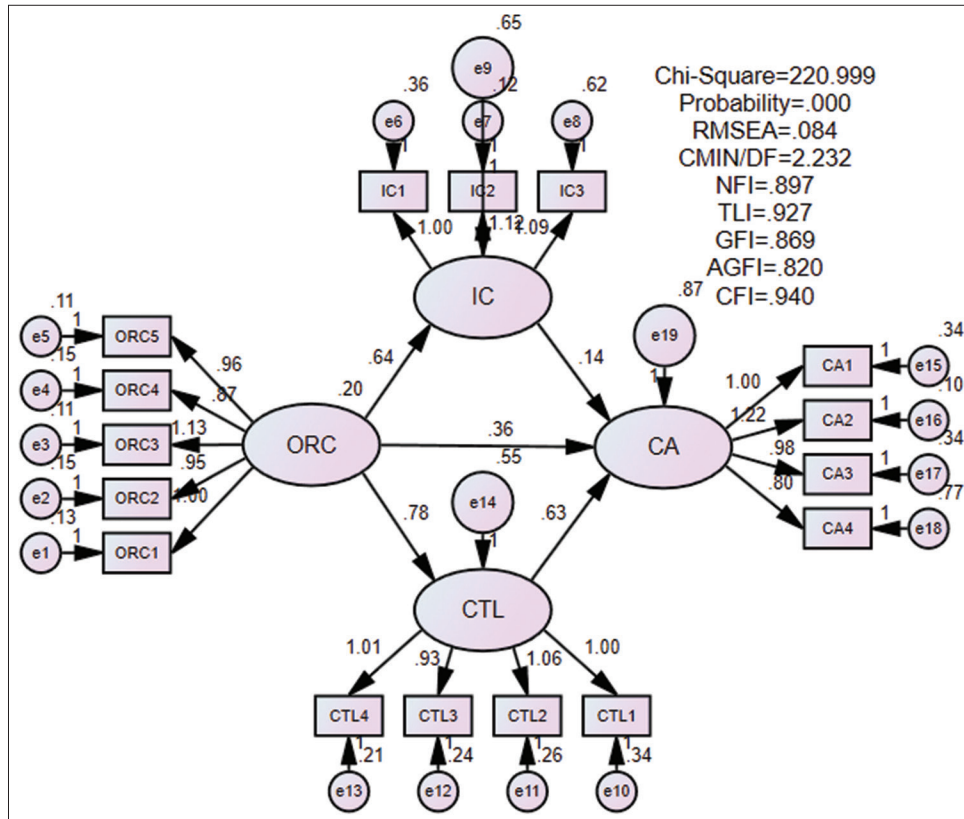

Table 2: Hypothesis testing

Hypothesis			Estimate	SE	CR	P-value
Eco-Innovation Capability	←	Green intellectual capital	0.639	0.154	4.144	***
Transformational Leadership	←	Green intellectual capital	0.642	0.125	5.138	***
Green Competitive Advantage	←	Green intellectual capital	0.393	0.217	1.814	0.070
Green Competitive Advantage	←	Transformational Leadership	0.830	0.158	5.244	***
Green Competitive Advantage	←	Eco-Innovation Capability	0.156	0.119	1.314	0.189

and two-tailed probability significance values. There are two hypotheses that use mediating factors in this study, namely hypothesis six which states that Eco-Innovation Capability can mediate the relationship between Green intellectual capital and Green Competitive Advantage.

From the calculation results of the sixth hypothesis Sobel test, the Sobel value is 3.1778 with a one-tailed probability value of 0.0007 and a two-tailed probability value of 0.0014. The results show that the significance of each probability is below 0.05, which means that Eco-Innovation Capability is very suitable as a mediator between Green intellectual capital and Green Competitive Advantage. Therefore, the sixth hypothesis can be accepted. Then the Sobel test for the seventh hypothesis shows a Sobel value of 4.1814 with a one-tailed probability value and a two-tailed probability value of 0.0000. This means that Eco-Innovation Capability can mediate the relationship between Green intellectual capital and Green Competitive Advantage. With the results obtained, it can be concluded that the seventh hypothesis can be accepted. The results of the Sobel test for the sixth and seventh hypotheses are presented in Figures 3 and 4.

The findings are consistent with previous research. Singh et al. (2020) have highlighted the importance of green intellectual capital in promoting sustainable practices and transformational leadership. Also, the findings are in line with Omarova and Jo (2022) found that environmental knowledge and skills positively influence transformational leadership, while Ababneh (2021) stated that environmental values have a direct positive effect on employee engagement in sustainable practices. In the relationship between green intellectual capital and transformational leadership, the findings also in line with Yadiati et al. (2019) stating that green intellectual capital has a significant positive impact on transformational leadership, and that this relationship is mediated by environmental innovation. The results are in line with Demirel

and Kesidou (2019), the development of eco-innovation capabilities is critical for firms seeking to gain competitive advantage in the green organizations. Cai and Li (2018), Naruetharadhol et al. (2021) also found that organization with higher eco-innovation capabilities were more likely to offer sustainable management practices, reduce their carbon footprint, reduce costs through eco-efficiency, and create a positive reputation and image for the organization. The testing of mediating effect also showed that the findings are consistent with Xi et al. (2022), stating that transformational leadership plays a mediating role in the integration of green intellectual capital and competitive advantage.

### 5. CONCLUSION

The results of the study show that eco-innovation capability and transformational leadership can be directly influenced by green intellectual capital capabilities. The results of the analysis also show that green competitive advantage can also be directly influenced by transformational leadership. However, in this study green intellectual capital and eco-innovation capability do not have a direct significant effect on green competitive advantage. Therefore, a factor mediator is used to mediate the relationship between green intellectual capital and eco-innovation capability on green competitive advantage. The results are in line with previous studies demonstrating that collaborative governance is a way of managing public sector that involves all stakeholders, both directly and indirectly, oriented and deliberations occur in the collective decision-making process in order to achieve sustainable green city. This needs a consideration of collaborative governance emerged from the start and was created due to shared awareness due to the complexity and dependence between institutions in solving problems in the management of green city.

The study contributes to the existing literature on green intellectual capital by providing empirical evidence of the relationship between green intellectual capital and eco-innovation capability, transformational leadership, and green city management in public sector organizations. The findings of the study provide insights to public sector organizations on the significance of investing in green intellectual capital capabilities to enhance their eco-innovation capability, transformational leadership, and green city management. Lastly, the study emphasizes the importance of integrating green intellectual capital considerations that prioritize renewable energy into the strategic planning process of public sector organizations.

Figure 3: Sobel test of eco-innovation capability

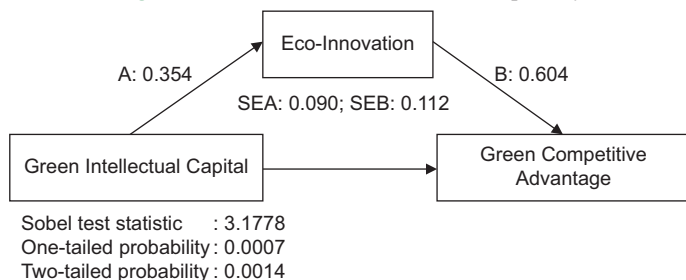
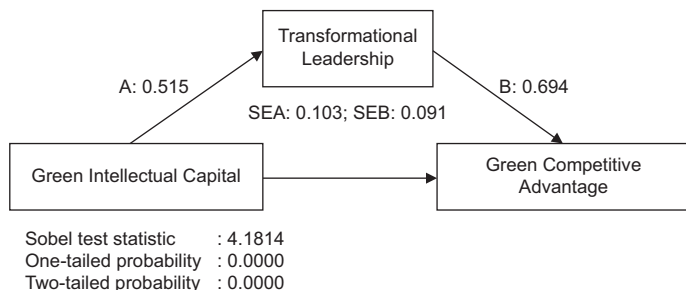

Figure 4: Sobel test of transformational leadership



### REFERENCES

Ababneh, O.M.A. (2021), How do green HRM practices affect employees' green behaviors? The role of employee engagement and personality attributes. *Journal of Environmental Planning and Management*, 64(7), 1204-1226.

Abbas, J., Sağsan, M. (2019), Impact of knowledge management practices on green innovation and corporate sustainable development: A structural analysis. *Journal of Cleaner Production*, 229, 611-620.

Avolio, B.J., Bass, B.M., Jung, D.I. (1999), Re-examining the components of transformational and transactional leadership using the Multifactor Leadership Questionnaire. *Journal of Occupational and Organizational Psychology*, 72(4), 441-462.

- Bag, S., Dhamija, P., Bryde, D.J., Singh, R.K. (2022), Effect of eco-innovation on green supply chain management, circular economy capability, and performance of small and medium enterprises. *Journal of Business Research*, 141, 60-72.
- Barrutia, J.M., Echebarria, C. (2015), Resource-based view of sustainability engagement. *Global Environmental Change*, 34, 70-82.
- Bass, B.M., Avolio, B.J. (1993), Transformational leadership and organizational culture. *Public Administration Quarterly*, 17, 112.
- Cai, W., Li, G. (2018), The drivers of eco-innovation and its impact on performance: Evidence from China. *Journal of Cleaner Production*, 176, 110-118.
- Chen, A.S.Y., Hou, Y.H. (2016), The effects of ethical leadership, voice behavior and climates for innovation on creativity: A moderated mediation examination. *The Leadership Quarterly*, 27(1), 1-13.
- Chen, J., Cheng, J., Dai, S. (2017), Regional eco-innovation in China: An analysis of eco-innovation levels and influencing factors. *Journal of Cleaner Production*, 100, 1-14.
- Chen, Y.S., Chang, C.H. (2013), The determinants of green product development performance: Green dynamic capabilities, green transformational leadership, and green creativity. *Journal of Business Ethics*, 116, 107-119.
- Chopra, M., Saini, N., Kumar, S., Varma, A., Mangla, S.K., Lim, W.M. (2021), Past, present, and future of knowledge management for sustainability. *Journal of Cleaner Production*, 328, 129592.
- Cruce, S., Servaes, M., Kluijtmans, T., Mertens, S., Schollaert, E. (2022), Linking environmentally-specific transformational leadership and employees' green advocacy: The influence of leadership integrity. *Corporate Social Responsibility and Environmental Management*, 29(2), 406-420.
- Demirel, P., Kesidou, E. (2019), Sustainability-oriented capabilities for eco-innovation: Meeting the regulatory, technology, and market demands. *Business Strategy and the Environment*, 28(5), 847-857.
- Galera-Quiles, M.D.C., Piedra-Muñoz, L., Galdeano-Gómez, E., Carreño-Ortega, A. (2021), A review of eco-innovations and exports interrelationship, with special reference to international agrifood supply chains. *Sustainability*, 13(3), 1378.
- Garau, C., Pavan, V.M. (2018), Evaluating urban quality: Indicators and assessment tools for smart sustainable cities. *Sustainability*, 10(3), 575.
- Garcés-Ayerbe, C., Rivera-Torres, P., Suárez-Perales, I. (2019), Stakeholder engagement mechanisms and their contribution to eco-innovation: Differentiated effects of communication and cooperation. *Corporate Social Responsibility and Environmental Management*, 26(6), 1321-1332.
- Hegazy, I., Seddik, W., Ibrahim, H. (2017), Towards green cities in developing countries: Egyptian new cities as a case study. *International Journal of Low-Carbon Technologies*, 12(4), 358-368.
- Huang, S.Y.B., Ting, C.W., Li, M.W. (2021), The effects of green transformational leadership on adoption of environmentally proactive strategies: The mediating role of green engagement. *Sustainability*, 13(6), 3366.
- Jia, J., Liu, H., Chin, T., Hu, D. (2018), The continuous mediating effects of GHRM on employees' green passion via transformational leadership and green creativity. *Sustainability*, 10(9), 3237.
- Kuo, F.I., Fang, W.T., LePage, B.A. (2022), Proactive environmental strategies in the hotel industry: Eco-innovation, green competitive advantage, and green core competence. *Journal of Sustainable Tourism*, 30(6), 1240-1261.
- Naruetharadhol, P., Srisathan, W.A., Gebombut, N., Ketkaew, C. (2021), Towards the open eco-innovation mode: A model of open innovation and green management practices. *Cogent Business and Management*, 8(1), 1945425.
- Niazi, U.I., Nisar, Q.A., Nasir, N., Naz, S., Haider, S., Khan, W. (2023), Green HRM, green innovation and environmental performance: The role of green transformational leadership and green corporate social responsibility. *Environmental Science and Pollution Research International*, 30, 45353-45368.
- Nijkamp, P., Perrels, A. (2014), *Sustainable Cities in Europe*. London: Routledge.
- Omarova, L., Jo, S.J. (2022), Employee pro-environmental behavior: The impact of environmental transformational leadership and GHRM. *Sustainability*, 14(4), 2046.
- Qu, X., Khan, A., Yahya, S., Zafar, A.U., Shahzad, M. (2022), Green core competencies to prompt green absorptive capacity and bolster green innovation: The moderating role of organization's green culture. *Journal of Environmental Planning and Management*, 65(3), 536-561.
- Ray, S., Ray, I.A. (2011), Impact of population growth on environmental degradation: Case of India. *Journal of Economics and Sustainable Development*, 2(8), 72-77.
- Simpson, R., Zimmermann, M., editors. (2012), *The Economy of Green Cities: A World Compendium on the Green Urban Economy*. Germany: Springer Science and Business Media.
- Singh, S.K., Del Giudice, M., Chierici, R., Graziano, D. (2020), Green innovation and environmental performance: The role of green transformational leadership and green human resource management. *Technological Forecasting and Social Change*, 150, 1-12.
- Sun, X., El Askary, A., Meo, M.S., Zafar, N.U.A., Hussain, B. (2022), Green transformational leadership and environmental performance in small and medium enterprises. *Economic Research-Ekonomika Istraživanja*, 35(1), 5273-5291.
- Teixeira, A.A., Jabbour, C.J.C., de Sousa Jabbour, A.B.L., Latan, H., de Oliveira, J.H.C. (2016), Green training and green supply chain management: Evidence from Brazilian firms. *Journal of Cleaner Production*, 100, 170-176.
- Ullah, H., Wang, Z., Mohsin, M., Jiang, W., Abbas, H. (2022), Multidimensional perspective of green financial innovation between green intellectual capital on sustainable business: The case of Pakistan. *Environmental Science and Pollution Research International*, 29(4), 5552-5568.
- Xi, M., Fang, W., Feng, T. (2022), Green intellectual capital and green supply chain integration: The mediating role of supply chain transformational leadership. *Journal of Intellectual Capital*, <https://doi.org/10.21203/rs.3.rs-1511069/v1>
- Yadiati, W., Nissa, N., Paulus, S., Suharman, H., Meiryani, M. (2019), The role of green intellectual capital and organizational reputation in influencing environmental performance. *International Journal of Energy Economics and Policy*, 9(3), 261-268.
- Yang, Z., Sun, J., Zhang, Y., Wang, Y. (2020), Synergy between green supply chain management and green information systems on corporate sustainability: An informal alignment perspective. *Environment, Development and Sustainability*, 22, 1165-1186.
- Yong, J.Y., Yusliza, M.Y., Ramayah, T., Fawehinmi, O. (2019), Nexus between green intellectual capital and green human resource management. *Journal of Cleaner Production*, 215, 364-374.
- Yusoff, Y.M., Omar, M.K., Zaman, M.D.K., Samad, S. (2019), Do all elements of green intellectual capital contribute toward business sustainability? Evidence from the Malaysian context using the Partial Least Squares method. *Journal of Cleaner Production*, 234, 626-637.
- Zahoor, Z., Latif, M.I., Khan, I., Hou, F. (2022), Abundance of natural resources and environmental sustainability: The roles of manufacturing value-added, urbanization, and permanent cropland. *Environmental Science and Pollution Research International*, 29(54), 82365-82378.
- Zheng, D., Chen, J., Huang, L., Zhang, C. (2013), E-government adoption in public administration organizations: Integrating institutional theory perspective and resource-based view. *European Journal of Information Systems*, 22, 221-234.