

DIGITALES ARCHIV

ZBW – Leibniz-Informationszentrum Wirtschaft
ZBW – Leibniz Information Centre for Economics

Helzhynsky, Ihor; Kutsiy, Stepan; Veryha, Andriy et al.

Article

Development of portable device for measurement of dynamic and static light-emission WOLED characteristics

Reference: Helzhynsky, Ihor/Kutsiy, Stepan et. al. (2021). Development of portable device for measurement of dynamic and static light-emission WOLED characteristics. In: Technology audit and production reserves 1 (1/57), S. 30 - 33.

<http://journals.uran.ua/tarp/article/download/225239/225413/514102>.

doi:10.15587/2706-5448.2021.225239.

This Version is available at:

<http://hdl.handle.net/11159/6777>

Kontakt/Contact

ZBW – Leibniz-Informationszentrum Wirtschaft/Leibniz Information Centre for Economics
Düsternbrooker Weg 120
24105 Kiel (Germany)
E-Mail: [rights\[at\]zbw.eu](mailto:rights[at]zbw.eu)
<https://www.zbw.eu/econis-archiv/>

Standard-Nutzungsbedingungen:

Dieses Dokument darf zu eigenen wissenschaftlichen Zwecken und zum Privatgebrauch gespeichert und kopiert werden. Sie dürfen dieses Dokument nicht für öffentliche oder kommerzielle Zwecke vervielfältigen, öffentlich ausstellen, aufführen, vertreiben oder anderweitig nutzen. Sofern für das Dokument eine Open-Content-Lizenz verwendet wurde, so gelten abweichend von diesen Nutzungsbedingungen die in der Lizenz gewährten Nutzungsrechte.

<https://zbw.eu/econis-archiv/termsfuse>

Terms of use:

This document may be saved and copied for your personal and scholarly purposes. You are not to copy it for public or commercial purposes, to exhibit the document in public, to perform, distribute or otherwise use the document in public. If the document is made available under a Creative Commons Licence you may exercise further usage rights as specified in the licence.

Ihor Helzhynsky,
Stepan Kutsiy,
Andriy Veryha,
Khrystyna Ivaniuk,
Taras Dudok

DEVELOPMENT OF PORTABLE DEVICE FOR MEASUREMENT OF DYNAMIC AND STATIC LIGHT-EMISSION WOLED CHARACTERISTICS

The research object of this work is the parameters of organic light-emitting diodes, namely power and luminous flux. Determination of these parameters can be carried out using a photodiode and requires measuring the dark current of the sensor (photodiode), measuring the current of the photodiode when illuminated by the LED under investigation. And also take into account the relationship between the light flux received by the sensor and its output current, and take into account the spectral characteristics of the sensor. Calculate the investigated parameters of the LED based on the measurements. Carrying out these measurements requires laboratory instruments and workplace organization, and further calculations are routine work.

It is possible to increase the measurement accuracy by improving the existing methods for measuring the required parameters, and it is possible to automate the process of measurements and calculations using a modern microprocessor radioelement base. Microcontrollers are widespread such radioelements. They have the necessary peripherals for independent operation and have sufficient computing power to implement the required measuring device. Its application makes it possible to automate the measurement process, carry out the necessary calculations, save correction constants, accumulate and process the obtained data, analyze these received data, exchange data with a computer, etc. So, the work is aimed at developing a methodology that will allow the simultaneous measurement of power and luminous flux of planar light sources. And also on the feasibility of this technique in the device and software with the ability to measure the power of the light source in an arbitrary band of the spectral visible range. Thus, it is possible to determine what power in watts a light source emits with the dynamics of supply currents in the optical bands, knowing the spectrum of this source without using glass filters. So, the result of applying the technique is to determine the power of light radiation (in watts) or the luminous flux (in lumens) of the emitter (light sources).

Keywords: optical bands, LED radiation power, WOLED, microcontroller software.

Received date: 22.10.2020

Accepted date: 10.12.2020

Published date: 26.02.2021

© The Author(s) 2021

This is an open access article under the CC BY license

(<http://creativecommons.org/licenses/by/4.0>)

1. Introduction

It is generally accepted that when choosing a light source, consumers tend to focus on the higher energy efficiency of light sources. Compared to traditional light sources, inorganic LEDs demonstrate a fairly high efficiency, which at present can be almost twice as high as that of fluorescent lamps [1]. When it comes to color quality, both inorganic LEDs and fluorescent lights have at least two disadvantages. The first drawback is the rather low color rendering index (CRI) [2], that is, a measure of the ability of a light source to adequately reflect the colors of illuminated objects, compared to a natural light source. The second drawback is the shift of radiation to the blue region of the spectrum, which to a certain extent is dangerous to human health [3]. In this context, in organic light-emitting diodes, white radiation (WOLED) harmful blue radiation can be largely eliminated by design and technology approaches [4]. So, WOLED, as an alternative light source, demonstrates comparable performance and at the same time better color rendering quality, is definitely an extremely promising basic element of the latest lighting systems. Taking into account

that one of the fundamental parameters of light sources as an element of a lighting system is power and luminous flux as a quantitative characteristic of radiation. In terms of shelf life, typically LT50, LT70 and LT95 are used to confirm the reliability of WOLED, which means a decrease in brightness, respectively, to 50 %, 70 % and 95 % [5]. It is important to constantly monitor these parameters during the operation of WOLED lighting systems. Thus, *the object of research* is the parameters of organic light-emitting diodes, namely power and luminous flux. And *the aim of research* is to develop a portable device that makes simultaneous measurement of power and luminous flux.

2. Methods of research

The main essence of the technique is a certain dualism – it provides for the measurement of both power (PowerMeter) and luminous flux (Lux meter). The technique is implemented as follows:

- measurements and standardization of the source spectrum are carried out;
- the sensor sensitivity is normalized;

- the signal from the sensor is measured, including when the parameters of the light source are changed;
- the power of the source and the luminous flux created by the sensor are calculated (including when changing the parameters of the light source).

The main advantage of the technique, implemented in a portable device and software, is the ability to measure the power of a planar light source in an arbitrary band of the spectral visible range. Thus, it is possible to determine what power in watts the source gives in the bands, for example, 480÷510 nm and 630÷650 nm, knowing the spectrum of this source without the use of glass filters and the problems associated with them.

So, the purpose of the method is to determine the power of light radiation (in watts) or the luminous flux (in lumens) of the emitter (light sources) either «statically» (without changing the source parameters) or «dynamically» (with changing the source parameters).

The measurement technique can be used for a particularly «delicate» setting of the parameters of the light source in order to achieve the required value of the light radiation power (or luminous flux). That is, it is possible to determine what parameters of the light source should be set in order to achieve the required power of light radiation (in watts) or luminous flux (in lumens) for certain scientific or economic (applied) problems.

In the case when the luminous flux is not monochromatic, the dependence of the quantum efficiency on the wavelength should be taken into account. To solve this problem, it is necessary to have information about:

- spectral distribution of the radiation source ($I(\lambda)$ – dependence of intensity on wavelength);
- dependence of the quantum efficiency of the sensor on the wavelength ($S(\lambda)$ – dependence of the quantum efficiency on the wavelength).

For this, the dependence of the quantum efficiency of the sensor (Hamamatsu) on the wavelength in the range of 340÷800 nm is taken into account.

The spectral distribution can be obtained using the available spectrometer. This section is subject to post-processing:

- smoothing (elimination of accidental emissions, etc.);
- «cleaning» the constant component;
- rationing.

The result is a dependence of the intensity on the wavelength, suitable for practical use. This allows one to calculate the contribution of each spectrum component to the total sensor response. Knowing the contribution of each spectrum component to the total sensor response and the quantum efficiency for each of these components, it is obvious to calculate the total normalized quantum efficiency for a given radiation source:

$$P_g = \frac{S}{S_n} [W], \quad (1)$$

where P_g – total power; S – sensor feedback; S_n – normalized quantum efficiency of the sensor.

Thus, to correctly measure the radiation power, it is necessary to calculate the effective quantum efficiency for each type of radiation source.

3. Research results and discussion

3.1. Practical implementation of the device. The main unit of the device circuit is the measuring chamber, the

circuit of which is shown in Fig. 1. It is made of cylindrical billet aluminum. A cone is machined inside, the base diameter of which is such that an optical sensor of the S2387-1010R [6] or S7686 [7] brand (Japan) is tightly fixed into it. The top of the cone has a diameter slightly larger than the diameter of the diode, the parameters of which are subject to investigation.

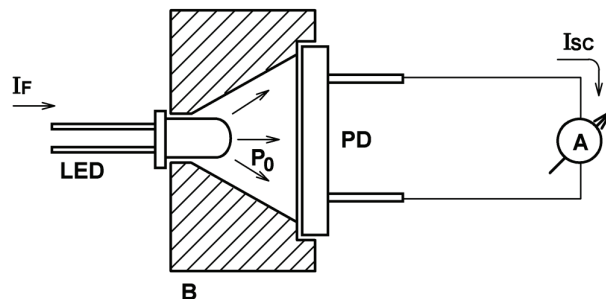

Fig. 1. Diagram of the camera for measuring the LED total emission: A – ammeter with a measurement range of 1÷10 mA; PD – S2387-1010R sensor; B – aluminum block is covered with gold inside

The total power of the luminous flux emitted by the investigated LED is determined as:

$$P_0 \approx \frac{I_{sc}}{S} [W], \quad (2)$$

where P_0 – total emission; I_{sc} – photodiode current; S – photosensitivity of the silicon photodiode, based on the spectral response graph in the documentation for the S2387-1010R: $S \approx 0.58$ A/W ($\lambda = 930$ nm), or for S7686: $S \approx 0.38$ A/W ($\lambda = 550$ nm).

The PD sensor is connected to the electrical circuit of the pre-amplifier, which has the ability to correct «zero» and adjust the gain (Fig. 2). The preamplifier is assembled on the TLC271 operational amplifier (USA) [8]. The voltage at the output of the amplifier is proportional to the current flowing through the WOLED and fed to a voltmeter or other meter. In the feedback link, it is possible to switch between the measurement ranges by connecting resistors of different ratings. The VR calibrating slide resistor compensates for the sensor's dark current and sets it to zero.

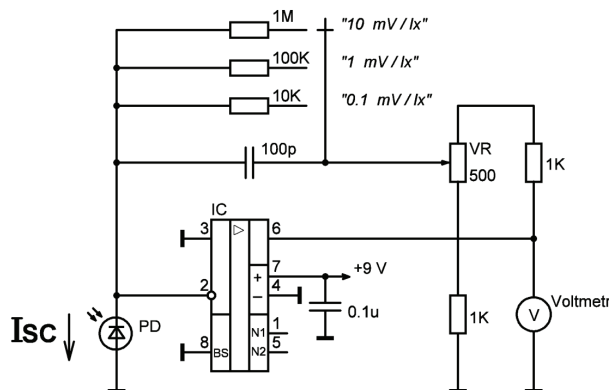

Fig. 2. Electrical functional diagram of the preamplifier of the luminometer: VR – calibrating paddle resistor; IC – TLC271 operational amplifier microcircuit; PD – S2387 sensor (68 μ A/100 lx) or S7686 sensor (0.45 μ A/100 lx)

The use of a microcontroller (single-chip electronic computing machine (computer)) allows automating the

measurement process, carrying out the necessary calculations, saving correction constants, accumulating and processing the obtained data, analyzing these received data, exchanging data with a computer, etc. The electrical functional diagram of the luminometer device on based on the microcontroller is shown in Fig. 3.

The device consists of the following functional units: controller – platform «Arduino UNO» (India) [9], liquid crystal display, photodetector Hamamatsu S2387 (Japan), current amplifier with controlled gain, power supply. All units of the device are controlled by a microcontroller.

The microcontroller generates an analog voltage proportional to the digital code through a digital-to-analog converter (DAC). This voltage is amplified by a voltage amplifier (VA) and thus controls the operation of the LED under study. Further, the signal from the sensor (PD) is amplified by a preamplifier with a controlled gain. The selection of the gain is carried out by keys K0-K3, which in turn are guided by the microcontroller. The amplified analog signal is converted by an analog-to-digital converter (ADC), the digitized signal is processed by the microcontroller according to the programmed algorithm.

The operation of the device is controlled from the keyboard connected to the microcontroller, and information about the operating modes and settings is displayed on the display. Data exchange with the computer is carried out via the COM port interface.

In general, the device perfectly measures the sensor current. Current measurement ranges (dynamic range of each range – 1024 discrete levels):

- I1 (max) up to 100 μ A;
- I2 (max) up to 200 μ A;
- I3 (max) up to 500 μ A;
- I4 (max) up to 1000 mA.

The device operation algorithm has the following sequence:

- setting the minimum gain (current measurement range up to 1000 mA) – the so-called test measurement;
- measurement of the sensor currents when the signal of the light source setting the operating parameter changes (from 0 to 3÷15 volts, set by the user, 250 discrete values in the specified range) using a digital filter for «tuning out» from interference and noise. Also, the data are averaged for each parameter of the source;

- determination of the maximum signal $I_{0(max)}$ of the sensor and, if necessary, switching to another measurement range. Thus, the measurement range is selected, which will ensure the highest measurement accuracy. The dynamic range of the ADC is used optimally. Range selection criteria are: $I_{0(max)} \leq I_{i(max)} \cdot 0.8$ – so-called working measurement;
- the working measurement is transferred to the PC.

3.2. Software. Final calculations of the radiation power and brightness are carried out on a computer in the corresponding software developed (Fig. 4). In general, software consists of the following components:

- the controller software is implemented using The Arduino Integrated Development Environment – «Arduino Software (IDE)» [10];
- software (for PC) for communication with a microcontroller and calculation of effective quantum efficiency – environment «Visual Basic Microsoft Visual Studio Community 2019» [11].

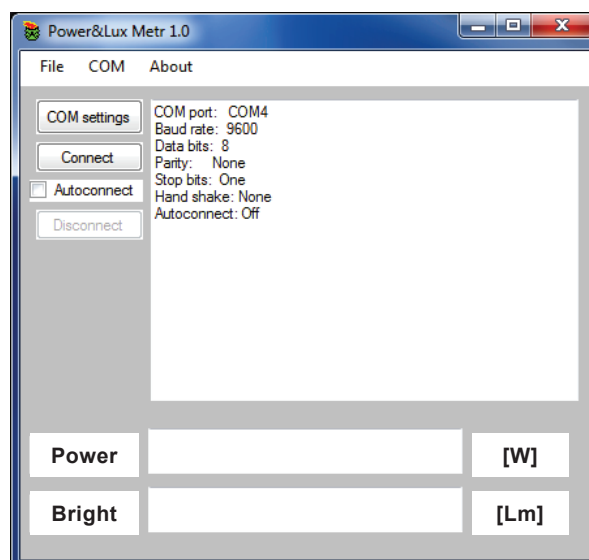

Fig. 4. Appearance of the interface of the program of interaction with the device

The software component can generally be broken down into three parts.

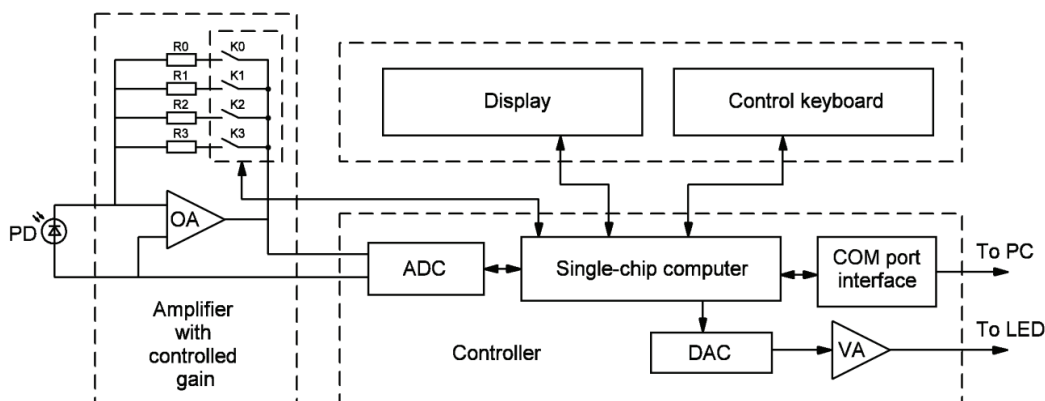

Fig. 3. Electrical functional diagram of the luminometer device:

PD – photodiode; OA – operational amplifier; R0-R3 – OA feedback supports (for changing the gain); K0-K3 – OA feedback resistance switches; ADC – analog-to-digital converter; DAC – digital-to-analog converter; VA – voltage amplifier; PC – personal computer; the power supply is not reflected

Part 1. Power measurement.

- (A) The device measures the photocurrent induced by the light source.
- (B) The spectrometer measures the dependence of the intensity of this source on the wavelength.
- (C) The dependence of the quantum yield of photodiodes on the wavelength is known from the documentation for the device (certified).
- Knowing the dependence of the distribution B and C, the contribution of each spectrum component to the total power of the light source is calculated and the total power of the light source is listed.

Part 2. Measurement of luminous flux.

- (A) The device measures the photocurrent induced by the light source.
- (B) The spectrometer measures the dependence of the intensity of this source on the wavelength.
- (C) The dependence of the quantum yield of photodiodes on the wavelength is known from the documentation for the device (certified).
- Knowing the dependences of the B and C distribution and taking into account the recommendations of the CIE (International Commission of Illumination), the contribution of each spectrum component to the total luminous flux created by the light source is calculated and the luminous flux created by the light source is calculated.

Part 3. Measurement of power in an arbitrary spectral range.

- (A) The device measures the photocurrent induced by the light source.
- (B) The spectrometer measures the dependence of the intensity of this source on the wavelength.
- (C) The dependence of the quantum yield of photodiodes on the wavelength is known from the documentation for the device (certified).
- Knowing the dependences of the distribution of B and C and taking into account the desired spectral range (the contribution of unnecessary sections is multiplied by zero), the contribution of each spectrum component to the total power of the light source is calculated and the power of the light source in the required spectral range is listed.

4. Conclusions

The proposed technique, implemented in a portable device, allows simultaneous measurement of power and luminous flux with the ability to measure the source power in an arbitrary band of the spectral visible range. A device for dynamic and static brightness measurement WOLED and software have been developed using the proposed technique, the advantage of which is that it is enough to measure the typical spectrum of a certain type of light source once. All measurements are carried out automatically.

A portable device with software can be used to measure the parameters of both point and plane light sources with different luminescence brightness and with different widths of the visible radiation spectrum, both for scien-

tific and economic purposes. The results of studies of the parameters of organic light-emitting diodes obtained using the proposed device will be used in the subsequent development of new and improvement of existing organic structures. The device can also be used in production for control and sorting by parameters of light-emitting radioelements before their installation into products.

References

1. Min-Hao Michael Lu, Hack, M., Hewitt, R., Weaver, M. S., Brown, J. J. (2008). Power Consumption and Temperature Increase in Large Area Active-Matrix OLED Displays. *Journal of Display Technology*, 4 (1), 47–53. doi: <http://doi.org/10.1109/jdt.2007.900924>
2. Park, Y.-S., Kim, K.-H., Kim, J.-J. (2013). Efficient triplet harvesting by fluorescent molecules through exciplexes for high efficiency organic light-emitting diodes. *Applied Physics Letters*, 102 (15), 153306. doi: <http://doi.org/10.1063/1.4802716>
3. Kamtekar, K. T., Monkman, A. P., Bryce, M. R. (2010). Recent Advances in White Organic Light-Emitting Materials and Devices (WOLEDs). *Advanced Materials*, 22 (5), 572–582. doi: <http://doi.org/10.1002/adma.200902148>
4. Jou, J.-H., Wu, R.-Z., Yu, H.-H., Li, C.-J., Jou, Y.-C., Peng, S.-H. et al. (2013). Artificial Dusk-Light Based on Organic Light Emitting Diodes. *ACS Photonics*, 1 (1), 27–31. doi: <http://doi.org/10.1021/ph400007w>
5. Sudheendran Swayamprabha, S., Dubey, D. K., Shah Nawaz, Yadav, R. A. K., Nagar, M. R., Sharma, A. et al. (2020). Approaches for Long Lifetime Organic Light Emitting Diodes. *Advanced Science*, 8 (1), 2002254. doi: <http://doi.org/10.1002/advs.202002254>
6. *Si photodiodes. S2387 series*. Available at: https://www.hamamatsu.com/resources/pdf/ssd/s2387_series_kspd1033e.pdf
7. *Si photodiodes. S7686 series*. Available at: [https://hamamatsu.eu/files/uploads/pdf/2_фотодиоды_и_ф_д_линейки/кремниевые_фотодиоды_\(si\)/одиночные_кремниевые/s7686_kspd1040e.pdf](https://hamamatsu.eu/files/uploads/pdf/2_фотодиоды_и_ф_д_линейки/кремниевые_фотодиоды_(si)/одиночные_кремниевые/s7686_kspd1040e.pdf)
8. *LinCMOS programmable low-power operational amplifier*. Available at: https://www.ti.com/lit/ds/symlink/tlc271.pdf?ts=1613384669139&ref_url=https%253A%252F%252Fwww.google.com%252F
9. *Arduino UNO*. Available at: <https://www.farnell.com/datasheets/1682209.pdf>
10. *Arduino Software (IDE)*. Available at: <https://www.arduino.cc/en/guide/environment>
11. *Visual Studio Community*. Available at: <https://visualstudio.microsoft.com/ru/vs/community/>

Ihor Helzhynsky, PhD, Associate Professor, Department of Electronic Devices, Lviv Polytechnic National University, Lviv, Ukraine, ORCID: <http://orcid.org/0000-0002-1931-6991>, e-mail: iigorg@ukr.net

Stepan Kutsiy, Postgraduate Student, Department of Electronic Devices, Lviv Polytechnic National University, Lviv, Ukraine, ORCID: <http://orcid.org/0000-0002-0757-6059>, e-mail: stepankutsiy@gmail.com

Andriy Veryha, PhD, Assistant, Department of Radio Engineering and Information Security, Yuriy Fedkovych Chernivtsi National University, Chernivtsi, Ukraine, ORCID: <http://orcid.org/0000-0002-2616-3057>, e-mail: veriga@ukr.net

Khrystyna Ivaniuk, PhD, Department of Electronic Devices, Lviv Polytechnic National University, Lviv, Ukraine, ORCID: <http://orcid.org/0000-0003-1264-3532>, e-mail: khrystyna.b.ivaniuk@lpnu.ua

Taras Dudok, PhD, Chief Engineer, Vlokh Institute of Physical Optics, Lviv, Ukraine, ORCID: <http://orcid.org/0000-0002-3793-6692>, e-mail: taras.dudok.2015@gmail.com