

DIGITALES ARCHIV

Mahzun, Ridwan

Other Persons: Thamrin, Thamrin; Bahruddin, Bahruddin; Nofrizal, Nofrizal

Article

Effect of ecological, economic and social factors on the implementation of ISO 14001 environmental management system in heavy industries in Indonesia

Provided in Cooperation with:

International Journal of Energy Economics and Policy (IJEPP)

Reference: Mahzun, Ridwan (2020). Effect of ecological, economic and social factors on the implementation of ISO 14001 environmental management system in heavy industries in Indonesia. In: International Journal of Energy Economics and Policy
<https://www.econjournals.com/index.php/ijeep/article/download/8984/5481>.
doi:10.32479/ijeep.8984.

This Version is available at:

<http://hdl.handle.net/11159/8054>

Kontakt/Contact

ZBW – Leibniz-Informationszentrum Wirtschaft/Leibniz Information Centre for Economics
Düsternbrooker Weg 120
24105 Kiel (Germany)
E-Mail: [rights\[at\]zbw.eu](mailto:rights[at]zbw.eu)
<https://www.zbw.eu/econis-archiv/>

Standard-Nutzungsbedingungen:

Dieses Dokument darf zu eigenen wissenschaftlichen Zwecken und zum Privatgebrauch gespeichert und kopiert werden. Sie dürfen dieses Dokument nicht für öffentliche oder kommerzielle Zwecke vervielfältigen, öffentlich ausstellen, aufführen, vertreiben oder anderweitig nutzen. Sofern für das Dokument eine Open-Content-Lizenz verwendet wurde, so gelten abweichend von diesen Nutzungsbedingungen die in der Lizenz gewährten Nutzungsrechte.

<https://zbw.eu/econis-archiv/termsfuse>

Terms of use:

This document may be saved and copied for your personal and scholarly purposes. You are not to copy it for public or commercial purposes, to exhibit the document in public, to perform, distribute or otherwise use the document in public. If the document is made available under a Creative Commons Licence you may exercise further usage rights as specified in the licence.



Effect of Ecological, Economic and Social Factors on the Implementation of ISO 14001 Environmental Management System in Heavy Industries in Indonesia

Ridwan Mahzun*, Thamrin, Bahrudin, Nofrizal

Universitas Riau, Pekanbaru, Jl. Pattimura No. 9, Pekanbaru, Riau 28131, Indonesia. *Email: ridwanmahzun.unri@gmail.com

Received: 16 October 2019

Accepted: 13 July 2020

DOI: <https://doi.org/10.32479/ijeeep.8984>

ABSTRACT

This study originally tried to examine the influence of ecological, economic and social factors on the implementation of an environmental management system by taking a case study in heavy industry from a shipyard in Batam Indonesia with reference to ISO 14001: 2015 Environmental Management System (EMS) standards. EMS is a framework that helps companies to manage the environmental impacts that arise from their activities. According to Law No. 32/2009, EMS includes policies on the arrangement, utilization, development, maintenance, recovery, supervision and control of the environment. The method used is Structural Equation Modeling (SEM), with a survey method by distributing questionnaires to respondents who know the work of the shipyard industry and the implementation of environmental management systems in this heavy industry. The study results show that economic and social factors have a positive effect on the application of ISO 14001 environmental management systems in Heavy Industries in Indonesia. These findings indicate the importance of applying ISO 14001 in heavy industry, in particular, and the importance of considering various ecological, social and economic conditions of the company in such implementation.

Keywords: Ecology, Social Factors, Environmental Management Systems, Heavy Industry, Indonesia.

JEL Classifications: Q57, Q56

1. INTRODUCTION

The environmental management system is a process that runs and interacts where the structure, responsibilities, procedures, processes and resources for the implementation of environmental policy targets and targets can be coordinated with businesses that already exist in other fields such as operational, health and work safety (Sunu, 2001). Sroufe (2003) states that an environmental management system is a system and database that integrates procedures and processes for training personnel, monitoring, summarizing, and reporting specific environmental performance information to internal and external stakeholders of a company. Hanoum (2000) describes an environmental management system as part of an overall management system that includes organizational structures, activity planning responsibilities,

practices, procedures, processes and resources to develop, implement, achieve, review and maintain environmental policies. ISO 14001 is an environmental management system that contains requirements specifications and guidelines for their use.

These reviews imply that the concept and implementation of environmental management standards is a long chain of activities. On the other hand, there are certain industries which are considered to have a major impact on environmental preservation both land, water and air as well. In this context, heavy industry such as shipyards needs to be pressed according to existing regulations to comply with and apply environmental management standards. This is because the shipyard industry is most likely to produce heavy metal waste. Heavy metals in

dangerous waters, both directly and indirectly, affect the life of organisms and human health. This relates to the properties of heavy metals which are difficult to be degraded so that it is easily accumulated in the aquatic environment and its presence is naturally difficult to decompose, can accumulate in organisms including shellfish and fish and will endanger the health of humans who consume these organisms (Rai, 2008). So it can be stated that besides having an impact on the economy and social, the shipyard industry has a considerable impact on the ecological environment.

Environmental damage in coastal areas is more dominated by rubbish, oil pollution waste, rubbish and materials left over from fabrication and steel construction processes, and others. The damage will largely affect human activities and the environment, such as the destruction of marine life, the threat of fishing settlements, the threat of fishermen's livelihoods and so on. Therefore, if this is not optimally addressed, it is feared that coastal and marine resources will be increasingly degraded. The existence of such a large impact on the economic, social and ecological environment needs to be dealt with as soon as possible for the existing impact. One of the countermeasures is to overcome the ecological impact with environmental management and monitoring efforts as stipulated in the UKL/UPL for some physical, chemical and health environmental components for workers and communities around the shipyard industry environment.

Environmental management in shipyards becomes a crucial problem when it is related to waste management, where the volume of waste correlates with the evolution and dynamics of environmental management including policies that are coherent with the objectives, criteria, size and investment costs. This becomes important by conducting cost/benefit analysis to determine the overall economic efficiency of business investment by considering direct economic efforts (investment costs) and indirect economic efforts, such as pollution costs, costs allocated to affected human health, environmental rehabilitation costs. The European Economic and Social Committee recommends that local Governments and shipyards in Europe operate in a safe and ecological environment (Buruiana, 2015; Odewumi and Ajisegiri, 2013).

This study originally attempted to examine the influence of ecological, economic and social factors on the implementation of an environmental management system by taking a case study in heavy industry from a shipyard in Batam Indonesia. It is motivated that one of the efforts to overcome the impact that occurs with the environmental damage caused by the shipyard industry is to implement better environmental management, one of which is by implementing an Environmental Management System (EMS). EMS is a framework that helps companies to manage the environmental impacts that arise from their activities. According to Law No. 32/2009, EMS includes policies on the arrangement, utilization, development, maintenance, recovery, supervision and control of the environment. One of the commonly used EMS frameworks is ISO 14001: 2015.

2. LITERATURE REVIEW AND HYPOTHESIS

2.1. Environmental Management in International Standards

According to ISO 14001: 2015 the environmental management system is a part of the overall management system which includes planning of organizational structure, activities, responsibilities, practices, procedures, processes and resources to develop, implement, achieve, review, and maintain environmental policies. ISO 14004 is an environmental management system that contains general guidelines regarding the principles, systems and supporting techniques. The ISO 14001 International Standard is a vehicle to guarantee the performance of the environmental management system. The ISO 14001 standard actually emerged as a result of the existence of several environmental issues that are often discussed in the community. These environmental issues are air pollution, water pollution, soil pollution, waste and hazardous materials, sound or noise and vibration, radiation, physical planning, use of materials or materials, use of energy and occupational safety and health of employees (Tatiya, 2010).

The definition of an environmental management system according to ISO 14001: 2015 is an environmental management system that has been recognized internationally with certificates issued by the Certificate Board under the coordination of the International Standards Organization. The environmental management system that uses ISO 14001 is an international standard that guarantees the performance of the environmental management system. ISO 14001 standard actually emerged as a result of the existence of several environmental issues that are often discussed in the community. These environmental issues are air pollution, water pollution, soil pollution, waste and hazardous materials, noise and vibration, radiation, physical planning, material use, energy use and employee safety and health.

ISO 14001 is a standard that integrates and balances business interests with the environment and is also an internationally agreed standard for environmental management system requirements. This standard helps organizations improve their environmental performance through more efficient use of resources and waste reduction, gaining competitive advantage and trust from stakeholders including customers. The environmental management system helps organizations identify, manage, monitor and control their overall environmental problems. This means that ISO 14001 can be easily integrated into the existing ISO management system. ISO 14001 is suitable for all types of organizations, be it individual companies, non-profit companies or governments. This requires that the organization considers all environmental problems related to its operations, such as air pollution, water and waste issues, waste management, soil pollution, climate change mitigation and adaptation, and resource use and efficiency.

According to Tibor and Feldman (1996), an environmental management system is part of a management system that includes organizational structure, activity planning, responsibilities, practices, procedures, processes and resources to develop, implement, achieve, study, and maintain environmental policies. In

other words, an environmental management system is a management system that plans, schedules, implements and monitors activities that aim to improve environmental performance, an environmental management system as part of an overall management system that includes organizational structure, responsibility planning activities, practices, procedures, processes and resources for developing, implementing, achieving, reviewing and maintaining environmental policies (Hanoum, 2000). According to ISO 14001: 2015 the environmental management system is part of the overall management system which includes planning organizational structure, activities, responsibilities, practices, procedure, processes and resources for developing, implementing, achieving, reviewing and maintaining environmental policies. Meanwhile, the definition of an environmental management system according to ISO 14001: 2015 is an environmental management system that has been internationally recognized with certificates issued by the Certificate Board under the coordination of the International Standards Organization.

ISO 14001 is a standard that integrates and balances business interests with the environment and is also an internationally agreed standard for environmental management system requirements. This standard helps organizations improve their environmental performance through more efficient use of resources and waste reduction, gaining competitive advantage and trust from stakeholders including customers. The environmental management system helps organizations identify, manage, monitor and control their overall environmental problems. This means that ISO 14001 can be easily integrated into the existing ISO management system. ISO 14001 is suitable for all types of organizations, be it individual companies, non-profit companies or governments. This requires that the organization considers all environmental problems related to its operations, such as air pollution, water and waste issues, waste management, soil pollution, climate change mitigation and adaptation, and resource use and efficiency.

2.2. The Concept of an Environmental Management System in Indonesia

In Indonesia, the EMS itself has been determined to be the national target listed in the Appendix to the Presidential Regulation of the Republic of Indonesia Number 59 of 2017 concerning the Implementation of Achieving Sustainable Development Goals (TPB/SDGs). The target indicator is an increase in the number of companies implementing ISO 14001 SNI certification until 2019. The target is a proxy of the 12.6 TPB target which is to encourage companies, especially large and transnational companies, to adopt

sustainable practices and integrate sustainability information in their reporting cycle. The 12.6 TPB Goal is part of Global 12 Goal, which is to guarantee sustainable production and consumption patterns.

Like all ISO management system standards, ISO 14001 includes the need for continuous improvement of organizational systems and approaches to environmental problems. The new standard has been updated, with major improvements such as improved environmental management in the organization's strategic planning process, greater input from leadership and a strong commitment to proactive initiatives that improve environmental performance. Indonesian National Standards (SNI) ISO 14001: 2015 is an international best practice, suitable to be a common criterion for sustainable practices for businesses in Indonesia, so that collaboration between central and regional agencies is needed to increase the application of SNI ISO14001: 2015 EMS.

Environmental management system (Environmental Protection and Processing) according to Law No. 32 of 2009 concerning Environmental Protection and Processing Article 1 Paragraph 2 is a systematic and integrated effort undertaken to preserve environmental functions and prevent environmental pollution and/or damage which includes planning, utilization, control, maintenance of supervision, and law enforcement. The environmental management system adheres to a PDCA (Plan-Do-Check-Act) system or a sustainable 'system.

Likewise Gastl (2008) states that the environmental management system follows the Plan-Do-Check-Act cycle, or PDCA, where the Plan-Do-Check-Act (PDCA) Relationship with 7 Principles of ISO 14001: 2015 can be seen in Figure 1.

The diagram shows the process of first developing an environmental policy, planning an environmental management system, and then implementing it. This process also includes checking the system and following it up. This model is sustainable because the environmental management system is a process of continuous improvement in which the organization is constantly reviewing and revising the system. The environmental management system is a continuous cycle of planning, implementing, evaluating and improving processes, which are organized in such a way that the business objectives of the company/government and environmental objectives can be integrated and synergized.

In Indonesia, ISO SNI 14001: 2015 is now the latest version of the Standard which has considered the risks and opportunities of

Figure 1: Relationship of Plan-Do-Check-Act (PDCA) with ISO 14001: 2015 principles

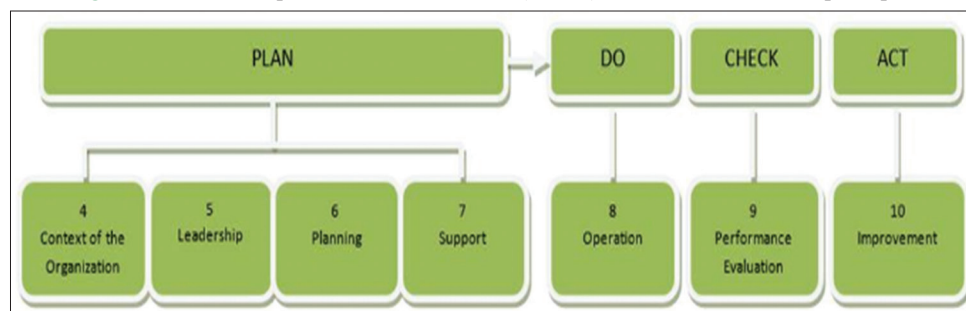

the organization's activities, products and services. By integrating it into business processes, this standard provides a reference for organizations to manage the environment while contributing to the environmental pillar of sustainable development. In addition, this standard has considered the life cycle perspective of activities, products and services starting from the extraction of raw materials, delivery, distribution, use, after being no longer used and final processing. Thus it is expected that all stages of the life cycle have taken environmental aspects into account. The ISWO SNI 14001: 2015 EMS is an environmental management standard adopted from the ISO 14001: 2015 Environmental Management System. The publication of this standard was preceded by the commitment of the International Business Council (WBCSD) who wants to contribute to the environment as a responsibility to improve environmental quality. The Indonesian vocal point of the environmental management standard of the ISLO SNI 14001: 2015 in the International Organization for Standardization (ISO) in the development of this standard is the National Standardization Body (BSN) and the substance content is in the Ministry of the Environment cq. Center for Environmental and Forestry Standardization.

2.3. Hypothesis

Narwal and Ajit (2014) states that aspects of emissions to air and water are the most significant environmental aspects in the Indian manufacturing industry with respect to severity ie the effects of these environmental aspects are more dangerous to humans. Likewise Chatzinikolaou and Ventikos (2014) in assessing the environmental impacts of ships from a life cycle perspective presents an assessment of the environmental impacts of the most important air emissions produced by oil tankers. Several previous studies also showed the relationship between ecological aspects and the implementation of environmental management systems, among others, by Liboni and Cezarino (2012), Integrated Report Committee (2014), Struwig and Lillah (2016), Moretti et al. (2017) and Nanok and Onyango (2017).

Meanwhile, Barasa (2015) sought to highlight how environmental and social aspects of monitoring related to the Olkaria II operation of the power plant were carried out by KenGen. Emphasis has been placed on how integration of ISO 14001 into environmental monitoring has been achieved. A study conducted by Basuki et al. (2016) shows that the impact on the environment which falls into the heavy category is dust due to the sandblasting process and odors due to the welding process.

H₁: Ecology has a positive effect on the implementation of EMS

Previous studies have suggested a link between economic aspects and the implementation of an environmental management system Liboni and Cezarino (2012) Integrated Report Committee (2014), Behera (2015), Struwig and Lillah (2016), Moretti et al. (2017) and Nanok and Onyango (2017). Likewise, several other studies such as those conducted by Hollands and Palframan (2014) state that significant barriers to further integration are identified in terms of cost, company structure and organizational size. Meanwhile, Irhoma et al. (2014) economic aspects in question is a matter of financial resources.

H₂: The economy has a positive effect on the implementation of EMS

Irhoma et al. (2014) that the social aspects referred to are more about leadership and poor management, external political constraints of organizational culture. Likewise, the results of previous research also support the assumption of a relationship between social aspects and the implementation of an environmental management system, among others, by Liboni and Cezarino (2012) Integrated Report Committee (2014), Behera (2015), Struwig and Lillah (2016), Moretti et al. (2017) and Nanok and Onyango (2017).

H₃: Social has a negative effect on the implementation of EMS

3. RESEARCH METHODS

This research was conducted in Batam Island, Riau Islands Province in several shipyard industries in Sagalung, Tanjung Uncang, Tanjung Pinggir, Sekupang, at the Batam Environment Office and the Batam City Environmental Development Office in 2018 and 2019. The number of samples was determined using the purposive method sampling of 100 respondents. The analysis technique used is for quantitative analysis also called verification analysis using the SEM (Structural Equation Modeling) statistical test from LISREL statisticians. The reason for using SEM (Structural Equation Modeling) according to Hair et al. (2006) is that using SEM allows analysis of a series of relationships simultaneously so as to provide statistical efficiency.

5. RESEARCH RESULTS

5.1. Overview of Research Locations

Batam is one of the big industrial cities in Indonesia, there are many industrial areas in the city of Batam. In addition to the manufacturing industry sector, Batam has many shipyard industries, fabrication industries and other heavy industries such as the pipe industry as well as the oil and gas support industry. The shipyard industry in Batam's free trade area and Batam's free port is the largest in Indonesia. There are many shipyard industries in the Tanjung Uncang, Sekupang and Kabil regions (Figure 2).

However, based on information obtained from the Batam Shipyard and Offshore Association (BSOA) that the shipyard industry in Batam is currently experiencing a decline of up to 80 percent. This is reinforced by the data of Bank Indonesia (2016) for the past 5 years, the contribution of ships and floating construction to the total exports of the Riau Islands tends to decline. The decline was affected by the crisis in the Middle East and the decline in orders for transporting mining vessels after the Minerba Act was enacted. In addition, previously the number of workers absorbed by the shipping industry sector in Batam reached 25 thousand people, so now only leaves around 11 thousand people, or reduced by around 14 thousand. Although this industry is still running, it has not been able to boost the development of this industry sector, including absorbing the number of workers so that it contributes to the reduction in unemployment in Batam. Table 1 shows data on the decline in the number of companies and employees of shipyards in Batam for the 2015-2017 period.

5.2. Goodness of Fit

GOF measurement results as presented in Table 2 show eight measurement models that provide conclusions that the structural

Figure 2: Map of Batam Island



relationship model between ecological aspects, economic aspects and social aspects and the implementation of EMS shows fit with actual data. This means that overall the relationship model built in this study is fit with the actual data on the research object. After knowing the conceptual model used in this study is fit with the actual data, then further testing of the hypothesis proposed in this study.

5.3. Hypothesis Testing

The next goal in the analysis of structural models is to estimate the parameters of influence between variables, which at the same time will also prove the research hypothesis. hypothesis testing results. SEM analysis using Lisrel software. The results of structural modeling can be seen in Figure 1.

Thus, the following structural equation can be obtained:

$$EMS = 0.204*CL + 0.493*EC + 0.290*SC,$$

$$\text{Errorvar.} = 0.360$$

$$R^2 = 0.640$$

CL = Ecological factor; EC= Economic factor; SC= Social factor; EMS= Implementation of EMS

From the first equation, as shown in Figure 3, it can be explained that the direction of ecological, economic and social relations with the implementation of EMS is positive. In other words, the SEM analysis

Figure 3: Standardized structural model

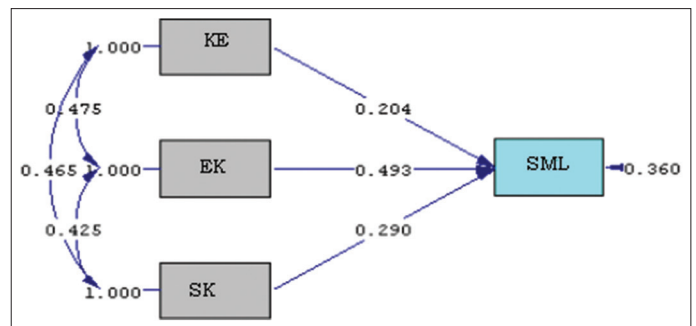

results obtained path coefficient from the ecological aspect of the environmental management system by 0.204, the path coefficient from the economic aspect to the environmental management system amounted to 0.493, and the path coefficient from the social aspect to the environmental management system amounted to 0.290. together (coefficient of determination) ecological, economic and social aspects of the environmental management system of 0.640, so that the total effect of all aspects is equal to 64.0%.

In more detail, in testing the effect of ecology on the implementation of EMS, the coefficient value of standardized regression weight between ecological variable and the implementation variable of EMS is 0.204, meaning that ecological aspects influence the implementation of the Environmental Management System implemented by shipyard companies in Batam related to the impact of existing industries

Table 1: Number of Shipyards in Batam

Year	Number of companies	Number of employees
2015	68	25,000
2016	32	18,000
2017	12	11,000

Source: Batam Shipyard and Offshore Association (BSOA), 2018

Table 2: Goodness of fit testing research models

No.	Goodness of fit index	Cut-off value	Results	Conclusion
1	Chi-square	small	11.125	Good fit
2	Significant probability	≥ 0.05	0.129	Marginal fit
3	RMSEA	≤ 0.08	0.078	Good fit
4	GFI	≥ 0.90	0.871	Marginal fit
5	AGFI	≥ 0.90	0.828	Marginal fit
6	TLI	≥ 0.90	0.975	Good fit
7	NFI	≥ 0.95	0.968	Good fit
8	CFI	≥ 0.94	0.982	Good fit

The second test on the effect of the economy on the implementation of the EMS shows the standardized regression weight coefficient value between the economic variable and the Implementation variable of the EMS is 0.493, which means that the economic aspect influences the implementation of the Environmental Management System implemented by the shipyard company in Batam related to the impact of the existing industry.

The third test on the influence of social factors on the implementation of the EMS shows the value of the standardized regression weight coefficient between the social variable and the Implementation variable of the EMS is 0.290, which means that social aspects are influential in the implementation of the Environmental Management System implemented by the shipyard company in Batam related to the impact of the existing industry.

6. CONCLUSION

The findings show that ecological, economic and social factors influence the implementation of environmental management systems. In particular, the application of an integrated environmental management system is related to ecological, economic and social aspects, where the economic aspect has the highest correlation. The application of an integrated environmental management system in order to overcome the environmental impact of the implementation of the Environmental Management System of shipyard companies in Batam currently meets the requirements listed in the clauses in ISO 14001: 2015 although most shipyard companies in Batam do not yet have ISO 14001: 2015 certification.

Practically, the implementation of an environmental management system is related to ecological, economic and social aspects, so that in order to increase the role of the environmental management system, companies need to increase the application of an environmental management system to mitigate the impact on ecological aspects, especially pollution from toxic and dangerous waste heavy metals arising from company activities. In addition, it is necessary to formulate an environmental

management strategy based on the results of the application of an integrated environmental management system with 4 priorities consisting of understanding the need for human resources in the organizational context, efforts to manage industrial waste, providing guidance, supervision in environmental management, developing an evaluation model and improving the system which is appropriate to the environment around the shipyard industry in Batam.

REFERENCES

- Barasa, P.J. (2015), Integration of Environmental Management System in Monitoring of Environmental and Social Aspects Associated with Operation of Olkaria II Geothermal Power Plant at Olkaria in Naivasha Sub-county, Nakuru County, Kenya. California: Proceeding Stanford Geothermal Workshop, SGP-TR-204. p10.
- Basuki, M. (2016), Penilaian risiko lingkungan (environmental risk assessment) pada pekerjaan reparasi kapal di perusahaan galangan kapal subklaster Surabaya. Prosiding Seminar Nasional Aplikasi Sains dan Teknologi, 1(1), 567-570.
- Behera, P.K. (2015), Socio-economic impact of industrialisation and mining on the local population: A case study of NALCO industrial area, Koraput. International Journal of Economics and Management Sciences, 4(273), 2.
- Buruiana, D. (2015), Development of Waste Management Systems in an Integrated Shipyard. Romania: University of Galati.
- Chatzinikolaou, S.D., Ventikos, N.P. (2014), Assessing environmental impacts of ships from a life cycle perspective. In: Proceedings of the 2nd International Conference on Maritime Technology and Engineering. Tamil Nadu: MARTECH. p15-17.
- Gastl, R. (2008), Kontinuierliche Verbesserung im Umweltmanagement: Die KVP-forderung der ISO 14001 in Theorie und Unternehmenspraxis. Switzerland: VDF Hochschulverlag AG.
- Hanoum, M.A. (2000), Manfaat Implementasi Sistem Manajemen Lingkungan ISO 14001 pada PT. Cikampek, Indonesia, Pupuk Kujang, Jawa Barat: Thesis Faculty of Agriculture Bogor Agricultural University.
- Irhoma, A., Su, D.Z., Higginson, M. (2014), Analysis of the barriers to environmental management systems implementation in the Libyan oil industry. Key Engineering Materials 572, 672-677.
- Liboni, L.B., Cezarino, L.O. (2012), Social and environmental impacts of the sugarcane industry. Future Studies Research Journal, 4(1), 196-227.
- Moretti, L., Di Mascio, P., Bellagamba, S. (2017), Environmental, human health and socio-economic effects of cement powders: The multicriteria analysis as decisional methodology. International Journal of Environmental Research and Public Health, 14(6), 645-655.
- Nanok, J.K., Onyango, C.O. (2017), A socioeconomic and environmental analysis of the effects of oil exploration on the local community in Lokichar, Turkana county, Kenya, International Journal of Management, Economics and Social Sciences, 6(3), 144-156.
- Narwal, M.S., Ajit, R.B. (2014), An analysis of environmental impacts of various environmental aspects for Indian manufacturing industries. International Journal of Research in Engineering and Technology, 3(3), 291.
- Odewumi, S., Ajisejiri, M. (2013), An appraisal of environmental health and safety management in the workplace (a study of continental shipyard limited). Asian Journal of Natural and Applied Sciences, 2(2), 145-158.
- Rai, P.K. (2008), Heavy metal pollution in aquatic ecosystems and its phytoremediation using wetland plants: An ecosustainable approach.

- International Journal of Phytoremediation, 10(2), 133-160.
- Sroufe, R. (2003), Effects of environmental management systems on environmental management practices and operations. *Production and Operations Management*, 12(3), 416-431.
- Struwig, M., Lillah, R. (2016), Factors influencing business implementation of environmental management systems. *Journal of Economics, Business and Management*, 4(4), 272-279.
- Sunu, P. (2001), *Melindungi Lingkungan Dengan Menerapkan ISO 14001*. Jakarta: Gramedia.
- Tatiya, R.R. (2010), *Elements of Industrial Hazards: Health, Safety, Environment and Loss Prevention*. United States: CRC Press.
- Tibor, T., Feldman, I. (1996), *Implementing ISO 14000: A Practical, Comprehensive Guide to the ISO 14000 Environmental Management Standards*. New York: McGraw-Hill.