

DIGITALES ARCHIV

ZBW – Leibniz-Informationszentrum Wirtschaft
ZBW – Leibniz Information Centre for Economics

Sarjiya; Putranto, Lesnanto Multa; Irnawan, Roni et al.

Article

Assessing potential scenarios for achieving new and renewable energy targets in Java-Bali Power System, Indonesia

Provided in Cooperation with:

International Journal of Energy Economics and Policy (IJEPP)

Reference: Sarjiya/Putranto, Lesnanto Multa et. al. (2022). Assessing potential scenarios for achieving new and renewable energy targets in Java-Bali Power System, Indonesia. In: International Journal of Energy Economics and Policy 12 (2), S. 502 - 515.
<https://econjournals.com/index.php/ijeep/article/download/12852/6718/30158>.
doi:10.32479/ijeep.12852.

This Version is available at:
<http://hdl.handle.net/11159/8799>

Kontakt/Contact

ZBW – Leibniz-Informationszentrum Wirtschaft/Leibniz Information Centre for Economics
Düsternbrooker Weg 120
24105 Kiel (Germany)
E-Mail: [rights\[at\]zbw.eu](mailto:rights[at]zbw.eu)
<https://www.zbw.eu/econis-archiv/>

Standard-Nutzungsbedingungen:

Dieses Dokument darf zu eigenen wissenschaftlichen Zwecken und zum Privatgebrauch gespeichert und kopiert werden. Sie dürfen dieses Dokument nicht für öffentliche oder kommerzielle Zwecke vervielfältigen, öffentlich ausstellen, aufführen, vertreiben oder anderweitig nutzen. Sofern für das Dokument eine Open-Content-Lizenz verwendet wurde, so gelten abweichend von diesen Nutzungsbedingungen die in der Lizenz gewährten Nutzungsrechte.

<https://zbw.eu/econis-archiv/termsfuse>

Terms of use:

This document may be saved and copied for your personal and scholarly purposes. You are not to copy it for public or commercial purposes, to exhibit the document in public, to perform, distribute or otherwise use the document in public. If the document is made available under a Creative Commons Licence you may exercise further usage rights as specified in the licence.



Assessing Potential Scenarios for Achieving New and Renewable Energy Targets in Java-Bali Power System, Indonesia

Sarjiya*, Lesnanto Multa Putranto, Roni Irnawan, Rizki Firmansyah Setya Budi

Department of Electrical and Information Engineering, Universitas Gadjah Mada, Yogyakarta, Indonesia. *E-mail: sarjiya@ugm.ac.id

Received: 15 December 2021

Accepted: 07 March 2022

DOI: <https://doi.org/10.32479/ijeep.12852>

ABSTRACT

Geographic circumstances, government policies, and power system characteristics face many countries struggling to achieve their new and renewable energy (NRE). In addition, one characteristic of renewable energy (RE) which cannot be moved is a severe problem for archipelagic countries like Indonesia in achieving their NRE targets. Therefore, this research creates a long-term open-source generation expansion planning (GEP) model that considers renewable energy integration between islands, government policies, and power system characteristics of Indonesia. The model proposes a high voltage direct current (HVDC) line to facilitate abundant energy transfer between islands. The research also included multiple scenario analyses based on the potential strategies that could realistically be applied. Based on the long-term GEP model results, possible alternative routes to achieving NRE targets are mapped and assessed by considering power system characteristics and national energy policies. Specifically, the Java-Bali system of Indonesia is employed as a case study to demonstrate the performance of the proposed long-term GEP model. The optimum planning to achieve the targets produces the generation cost of 7.05 cents USD/kWh and the CO₂ emission reduction of 2,297 million tons of CO₂.

Keywords: New and Renewable Energy Target, Resource Integration, Archipelagic Country, High Voltage Direct Current

JEL Classifications: C61, C63, D21, E39

1. INTRODUCTION

Global population growth and the rapidly expanding economies of developing countries have generated increased demand for electricity. Many countries, e.g., China (Musa et al., 2018), India (Saini et al., 2016), Indonesia (Khalil et al., 2019), Mexico (Pérez-Denicia et al., 2017), and South Africa (Lawrence, 2020), still depend on fossil energy. This dependence is problematic due to limited resources, increased fossil fuel prices, and CO₂ emissions (Sarjiya et al., 2020a). Limited fossil resources and increased fuel prices negatively impact fossil-fueled power plants. At the same time, CO₂ emissions lead to global warming and climate change.

Global warming and climate change have become critical problems in the last decade. Consequently, all countries are seeking to reduce their CO₂ emissions, especially in the electricity generation sector.

Therefore, replacing fossil-fueled power plants with alternatives that generate lower CO₂ emissions based on unlimited or renewable energy resources is necessary. Renewable energy use in the power sector is accelerating every year and accounts for 33% of installed power plant capacity (REN, 2019). The renewable power plants have been demonstrated to be environmentally friendly, with negligible CO₂ emissions. The generation cost of renewable power plants also continues to decline from year to year (Elia et al., 2020). Therefore, renewable power plants are excellent candidates to replace fossil-fueled power plants.

Because of the ability to replace fossil-fueled power plants, many countries have set their renewable targets. Unfortunately, achieving their renewable targets is not an easy task for developing countries. Many problems arise and become obstacles in achieving these targets (Sarjiya et al., 2020b). Furthermore, the issues

faced by developing countries differ depending on geographic circumstances (Budi et al., 2020a), government policies (Bersalli et al., 2020), and power system characteristics. Therefore, the renewable energy development model must consider those factors to obtain an optimal and feasible renewable energy development roadmap.

Renewable energy is an energy type whose source is geographically fixed and cannot be moved. This source characteristic limits its utilization and requires efforts to distribute renewable energy from its sources to the load centre, especially for archipelagic countries (Budi et al., 2019). The efforts become complicated when the load centres and renewable energy resources are located on different islands, as in Indonesia's case. One way to do so is by using high voltage direct current (HVDC) transmission. Although HVDC technology is suitable for power transmission across islands, the investment cost of HVDC is higher than high voltage alternating current (HVAC) (Elliott et al., 2016). Parameters that significantly affect the economy of HVDC are thus distance and the amount of transmitted power (Eeckhout et al., 2010). Therefore, an economic analysis is needed to assess HVDC technology's feasibility to deliver renewable energy across islands in the archipelagic country.

Besides the geographic circumstances, the government policies and power system characteristics need to be considered to create a renewable energy development roadmap. Combining these aspects leads to alternative strategies for increasing renewable energy use and creating a renewable energy development roadmap (Bersalli et al., 2020). The archipelagic country's renewable energy development model must consider its specific energy policies and power system characteristics to obtain the optimum renewable energy development roadmap. Therefore, a long-term generation expansion planning (GEP) model with a multi-scenario is required to effectively map and assess potential strategies to achieve the renewable energy targets and construct the development roadmap, especially in terms of optimality, sustainability, and feasibility.

Several studies have examined a long-term GEP model for achieving renewable energy targets. In (Mai et al., 2014), wind and solar energy maximization to fulfil electricity demand in the US were examined. In (Yang et al., 2019), a GEP model was created by considering energy policies that have sought to reduce dependence on imported energy resources. Economic growth and renewable energy (RE) development were analyzed using a GEP model developed in (Zhao et al., 2020). Implementing a hybrid generation technology as an alternative to support RE development was assessed in (Bagheri et al., 2018). However, these studies only focused on exploiting local renewable energy sources in a single system without considering the interconnection option and one scenario without comparing it with other potential scenarios. Therefore, the previous model cannot be used to solve these research problems.

In addition, many studies still use a long-term GEP model based on the licensed programs, such as HOMER (Sen and Bhattacharyya, 2014), LEAP (McPherson and Karney, 2014), MARKAL (Tsai and Chang, 2015), MESSAGE (Budi and Widodo, 2015), PLEXOS (Welsch et al., 2014), and WASP IV (Budi and Suparman, 2011).

Using a licensed model has problems in its flexibility and cost (Budi et al., 2020b). Therefore, an open-source model is required to solve these problems. The OSeMOSYS is an open-source model that has been widely used, and its validity can be proved (Howells et al., 2011a). Therefore this research uses the OSeMOSYS as the platform model.

This research creates and proposes a long-term GEP model for an archipelagic country that considers the interconnection option between islands, government policies, and power system characteristics. A multi-scenario analysis based on the potential strategies to achieve the renewable targets. The research aims to establish an open-source GEP model that considers inter-island interconnection options, government policies, and power system characteristics. Archipelagic countries can use the proposed model to assess their alternative solutions to achieve their renewable energy targets. The assessment is carried out from an economic perspective and in light of each scenario's advantages and disadvantages. The most appropriate solutions for developing renewable energy in archipelagic countries can be determined based on the assessment.

Because each archipelagic country has different problems that require different GEP models, this research uses a case study to evaluate the proposed model's performance model. Indonesia is chosen as the case study as it is an archipelagic country that has encountered various problems in developing renewable energy. Additionally, electricity demand in Indonesia continues to increase, growing by 5.1% per year on average (MoEMR, 2019). As of 2019, Indonesia's energy mix is still dominated by coal-fired power plants (37.15%), followed by oil (33.58%) and natural gas (20.13%) (National Energy Council, 2020). The uneven distribution of electricity demand and energy resources is another problem hindering power system development in Indonesia (Budi et al., 2019). Currently, the centre of Indonesia's power system is the Java-Bali system, constituting around 75% of national capacity (Budi et al., 2017).

The Indonesian power system also faces an additional problem: achieving the nation's new and renewable energy (NRE) targets within the Indonesian government's timeframe: 23% by 2025 and 31% by 2050 (Presiden of Republik Indonesia, 2014). The Java-Bali system is key to determining whether the national NRE targets will be successfully reached. More specifically, for the national NRE targets to be achieved, the Java-Bali system must reach its own NRE targets and vice versa (Sarjiya et al., 2020a). For this reason, the present study specifically evaluated the Java-Bali system in the Indonesian case study.

1.1. Novelty Offered

Based on the above explanations, the overview of this research and the novelty is shown in Figure 1. A long-term open-source GEP model for archipelagic countries with a multi-scenario is required to fill the research gap. Therefore, this research develops a long-term open-source GEP model based on archipelagic countries' geographic characteristics, energy policies, and power system characteristics. This long-term open-source GEP model is the novelty offered by this research. This research also provides

a novelty on mapping the potential scenarios and finding the optimum scenario to achieve the RE targets in the Java-Bali power system by considering the HVDC interconnection option. It is hoped that this study’s results can serve as a reference source for stakeholders involved in achieving RE targets.

This paper is structured as follows: Section 2 describes the modelling and scenario development, while Section 3 explains the methodology used to address the research problem. Section 4 describes the case study in the context of the research problem, after which the case study is assessed via the chosen methodology. Finally, Section 5 presents the results of this assessment and a discussion based on these results, while Section 6 offers some conclusions in light of the results and concerning the study context as a whole.

2. MODELING AND SCENARIO DEVELOPMENT

Solving the research problems requires the long-term open-source GEP model built by considering archipelagic countries, government policies, and power system characteristics. Before creating the model, the conceptual framework is constructed, as shown in Figure 2. First, modelling the energy transferred is required to solve the archipelagic country problem. Then, mapping the potential scenarios is used to obtain a comprehensive analysis by comparing the results of each scenario. Next, the scenarios are constructed based on the archipelagic country problems, government policies, and power system characteristics. Finally, after the energy transferred model and scenarios are obtained, the long-term open-source GEP

Figure 1: The research concept and its novelties offered

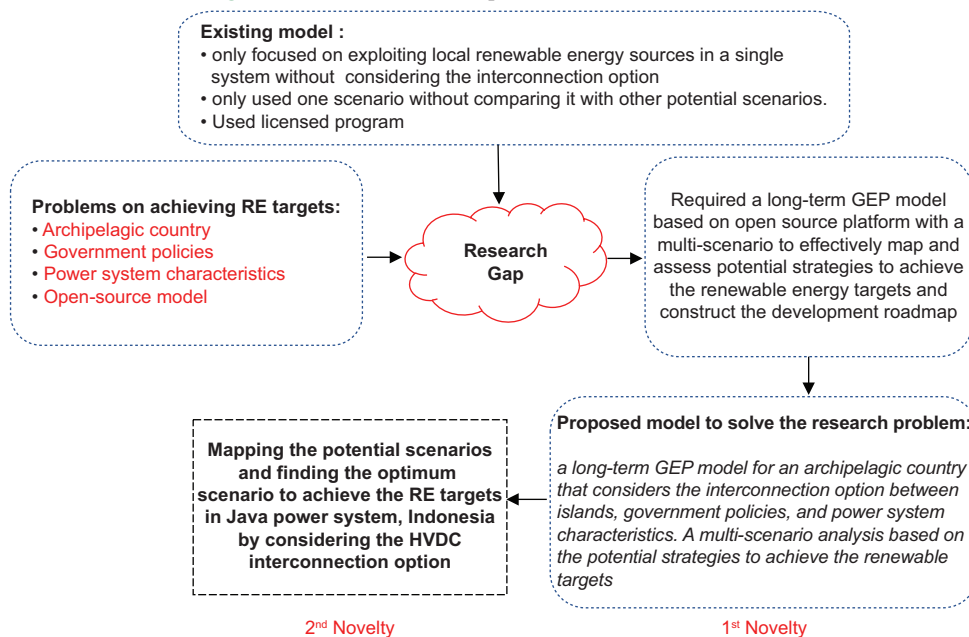
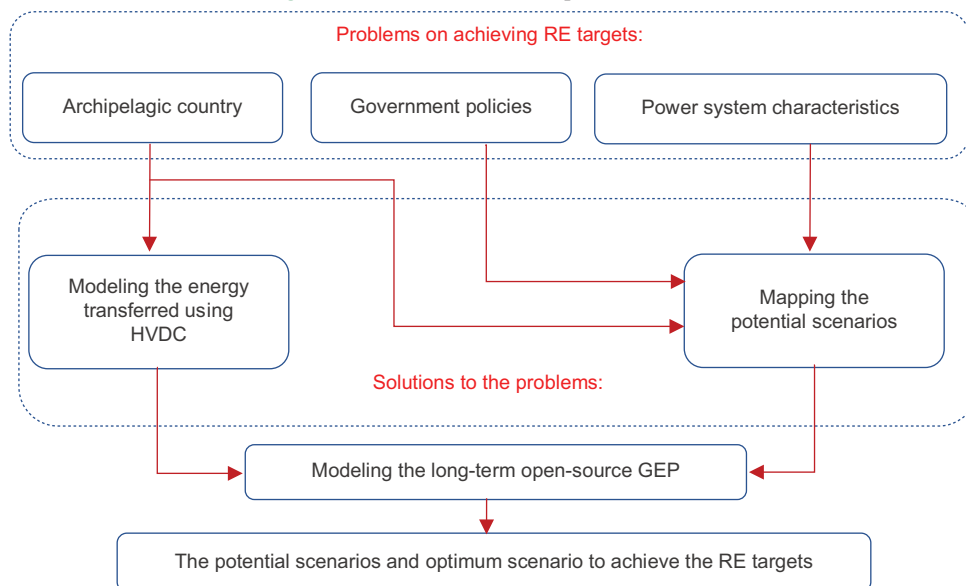

Figure 2: The research’s conceptual framework



model is built to get the optimum solution in achieving the RE targets and creating the RE development roadmap. All aspects required in the conceptual framework are described in this section.

2.1. Mapping Potential Scenarios

The Java-Bali system has potential RE resources on the order of 17.6 GW (MoEMR, 2016). However, considering the sheer size of the Java-Bali system, analysis is required to determine whether these resources are sufficient to meet the national RE targets. In addition, the feasibility of implementing alternative solutions in the Java-Bali system to achieve the RE target must also be mapped and assessed. One crucial consideration in this regard is the East Nusa Tenggara power system, located to the east of the Java-Bali power system, as shown in Figure 3.

The East Nusa Tenggara system has a much smaller electricity demand than the Java-Bali system, at only 0.4% of national capacity (MoEMR, 2019). However, the East Nusa Tenggara system has massive potential RE resources on 19 GW. Unfortunately, only 2.6 GW can feasibly be used to produce electrical energy (MoEMR, 2016). Specifically, only 10% of the system's solar and wind resources can feasibly be used, and only 60% of its hydro and geothermal resources can feasibly be used (National Energy Council, 2016). Nevertheless, the East Nusa Tenggara system still contains many potential RE resources, primarily because these resources have not been fully utilized due to small electricity demand. Therefore, the government brings up an idea to transfer the abundant RE resources through an interconnection line between the Java-Bali and East Nusa Tenggara power systems. Unfortunately, there is no economic study yet that can prove the financial benefit of this interconnection. Therefore, this research includes the interconnection as a scenario.

As described above, considering national energy policies and power system characteristics are crucial to creating potential scenarios. For instance, Indonesia's national energy policy considers several energy sources for achieving NRE targets: RE sources, such as wind, solar, geothermal, and hydropower, and new energy sources, such as nuclear power. However, nuclear power is considered a last option; i.e., this energy source is seriously considered when all other RE sources have been maximally used (National Energy Council, 2017). Reviewing its national energy policy, Indonesia appears to be a unique case compared to other countries. This uniqueness is because to reach its national RE target, Indonesia considers

RE and new energy as well. Therefore, it is more appropriate to describe the national RE targets as the NRE targets in Indonesia's case. Indonesia's NRE targets are at least 23% by 2025 and 31% by 2050 (National Energy Council, 2017).

The six scenarios are mapped and developed by considering the archipelagic country problems, government policies, and power system characteristics, as shown in Table 1. The Java-Bali scenario involves a situation in which the NRE targets are achieved via NRE development in the Java-Bali system without interconnection with the East Nusa Tenggara system. Conversely, the interconnection scenario involves achieving the NRE target by interconnecting the Java-Bali system with the East Nusa Tenggara system. These main scenarios consist of three sub-scenarios, i.e., BAU, NRE, and NRE, with nuclear as the last option. The BAU scenario does not involve the NRE targets policy. The NRE scenario involves the NRE targets policy intervention. In this scenario, all NRE resources are used to achieve the NRE targets. Lastly, the NRE with nuclear as the last option scenario involves the NRE targets policy intervention and considers nuclear energy as a last option. In this scenario, nuclear energy is only used when the other RE resources are depleted.

2.2. Energy Transfer Modeling Using HVDC

Initially, interconnections are modelled using HVAC technology. However, as the distance between the interconnected systems increases, the cost for such interconnections using HVAC technology increases significantly. Therefore, the HVDC is modelled for large interconnecting systems instead to solve the distance problem in the HVAC. The break-even distance offshore typically varies from 60 to 100 km (Eeckhout et al., 2010; Elliott et al., 2016). Two main types of HVDC converters exist LCCs and VSCs. A drawback of LCC-HVDC is the requirement for a strong AC grid (an AC grid with a short-circuit capacity of more than 3 times the converter's rating) for the thyristor bridge to be able to commute. Hence, the LCC-HVDC is used for long-distance power transmission that interconnects a strong AC grid with a large power plant, e.g., the Rio Madeira HVDC link.

On the other hand, the VSC-HVDC is more appropriate for use in offshore wind farm interconnections. In the last 5 years, 60% of new HVDC installations were VSC-HVDC, which is expected to increase in the future. Furthermore, in terms of multi-terminal HVDC operation, VSC-HVDC is the preferred technology over LCC-HVDC due to its capacity to reverse power direction without

Figure 3: The locations of the Java-Bali and East Nusa Tenggara power systems (Vemaps, 2020)



switching the polarity (Asplund et al., 2013). Hence, the HVDC technology suitable for future use in the Indonesia archipelago is VSC-HVDC technology.

The highest rating among installed VSC-HVDCs is ±525 kV and 1400 MW, i.e., the NordLink HVDC interconnection between Norway and Germany (ABB, 2015). It should be noted that these ratings are mainly dependent on the IGBT’s current rating, as illustrated in Table 2. This rating means that, in theory, M15x can deliver 3270 MW of active power along with the ±640 kV link, which is more than twice the power rating of NordLink.

There are already more than 170 HVDC links in operation today. However, each of these links is unique. It might be that each converter, although supplied by the same vendor, has various features or complexities depending on the AC grid’s condition and the station’s location. Hence, each installation has its price, as shown in Table 3 (Härtel et al., 2017).

In this research, the HVDC transmission line transfers the RE from the East Nusa Tenggara system to the Java-Bali system. The existing electricity grid in NTT is islanded, with a low generating capacity (<200 MW or 100 times lower than RE transferred potency). Hence, the appropriate HVDC technology needed to

transmit power to the Java-Bali system is the HVDC-VSC. If the classic or LCC technology is used, then the short-circuit capacity of the AC grid needs to be at least 3 times greater than the converter power rating (Jovicic and Ahmed, 2015). The interconnection started from a point in East Nusa Tenggara and is connected to Jakarta. This connection location is because Jakarta, as Indonesia’s national capital and economic centre, has a huge electricity demand. In addition, there is an unbalance electricity supply-demand between the East Java region with West Java region. Most of the demand is located in the West Java region. Meanwhile, most of the large power plant is located in the East Java Region. The unbalance creates a bottle-neck transmission problem. Therefore, if the interconnection point is located in Bali or East Java, it becomes a new burden for Java-Bali’s existing HVAC transmission line.

The interconnection used a voltage of 500 kV with a distance of approximately 1500 km. An illustration of this interconnection model is shown in Figure 4. If East Nusa Tenggara to Java-Bali transmission line possesses the same rating as NordLink (or NorthSeaLink), the converter price becomes 390–410 M€, and the line price becomes 1.2–1.5 M€/km.

2.3. Long-term Energy Planning

The OSeMOSYS consists of several block functions, where each block corresponds to an equation that can be adjusted based on the developing model (Howells et al., 2011b). The OSeMOSYS is written using GNU MathProg and simulated using the GNU Linear Programming Kit (GLPK) solver (Gardumi et al., 2018). The OSeMOSYS includes six core codes that focus on objective functions: costs, storage, capacity adequacy, energy balance, emissions, and constraints (Gardumi et al., 2018).

This research’s objective function is minimum levelized total costs, as shown in equation (1). The total costs consisted of capital costs (Inv_y), Operation and maintenance (O&M) costs, both fixed and variable ($O&M_y$), fuel costs ($Fuel_y$), and salvage value ($Salvage_y$). In the equation, y represents the year.

$$Obj. Function = \min \sum_y \left(\frac{Inv_y + O \& M_y + Fuel_y - Salvage_y}{(1+r)^y} \right) \quad (1)$$

Apart from the objective function, some constraints are also used, such as energy balance, reserve margin, and the RE share. These constraints are described in equations (2) to (4).

Table 1: Multiple scenarios of Java-Bali power system

Scenario	Description
Scenario without interconnection	
1.1	BAU scenario
1.2	NRE scenario
1.3	NRE with nuclear as the last option scenario
Scenario with interconnection	
2.1	Interconnection BAU scenario
2.2	Interconnection NRE scenario
2.3	Interconnection NRE with nuclear as the last option scenario

Table 2. VSC-HVDC Modules (ABB, 2017)

HVDC light symmetric modules	AC currents			
	580A _{AC}	1140A _{AC}	1740A _{AC}	2610A _{AC}
DC voltages (kV _{DC})				
±80	M1	M2	M3	M3x
±150	M4	M5	M6	M6x
±320	M7	M8	M9	M9x
±500	M10	M11	M12	M12x
±640	M13	M14	M15	M15x

Table 3: VSC-HVDC techno-economic figures (Härtel et al., 2017)

Project name	Rated Power (MW)	Line Length			Contracted Cost		
		SMC (km)	UGC (km)	OHL (km)	Line (M€)	Converter (M€)	Total (M€)
EstLink1	350	74	31	-		84.8	84.8
EWIC	500	186	76	-	291.1	130.6	421.7
NordBalt	700	400	13	40	268.7	169.9	438.6
Aland	100	158	-	-		99.1	99.1
Skagerrak4	700	138	92	12	127	131.9	258.9
NordLink	1400	516	54	53	936.5	395.9	1332.3
NorthSeaLink	1400	720	7	-	890	408.9	1298.9
COBRA	700	299	26	-	250	170	420
IFA2	1000	208	27	-	320.2	270	590.2

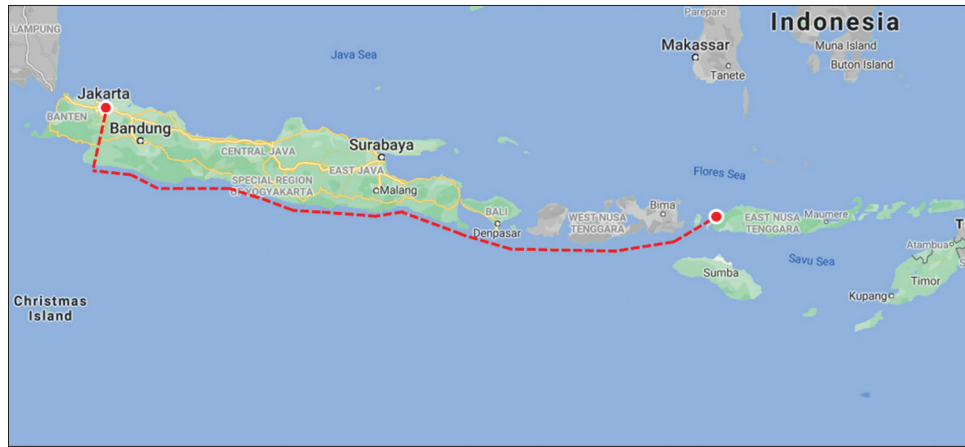
Figure 4: Illustration of interconnection model between the Java-Bali and East Nusa Tenggara systems (Google Map, 2020)

$$\text{Max capability of power plants}_y \geq \text{production}_y \geq \text{demand}_y \quad (2)$$

$$\text{Reserve margin}_y \geq 30\% \quad (3)$$

$$\text{RE production}_y \geq \text{RE Target}_y \quad (4)$$

The impact of long-term energy planning on the CO₂ emission reduction is also calculated to analyze energy planning contribution to the emission reduction. The CO₂ emission reduction is calculated using equations (5) to (7). While comparing the economics between energy planning results in each scenario, the research uses an LCOE that is calculated using equation (8).

$$\text{CO}_2 \text{ in the BAU scenario} = \text{Energy production}_t \times \text{Emission factor}_t \quad (5)$$

$$\text{CO}_2 \text{ in scenario}_N = \text{Energy production}_{N,t} \times \text{Emission factor}_{N,t} \quad (6)$$

$$\text{CO}_2 \text{ reduction} = \text{CO}_2 \text{ in the BAU scenario} - \text{CO}_2 \text{ in scenario}_N \quad (7)$$

$$\text{LCOE} = \frac{\sum_{t=0}^n \frac{\text{Investment}_t + O \& M_t + \text{Fuel}_t}{(1+r)^t}}{\sum_{t=0}^n \frac{\text{Energy production}_t}{(1+r)^t}} \quad (8)$$

3. RESEARCH METHOD

Based on the conceptual framework, the research method can be constructed, as shown in Figure 5. First, the research is begun by collecting the data required to build the long-term GEP model, such as power plant parameters, electricity demand, and energy resources. The following process is to set the scenario type. There are two main scenario types, i.e., a scenario without an interconnection option and a scenario with an interconnection option. Based on the main scenario types, the reference energy systems are constructed. The reference energy system of the Java-Bali power system without the interconnection is shown in Figure 6. In contrast, the reference energy system with the interconnection option is shown in Figure 7.

Figures 6 and 7 depict the energy flow from fuel combustion to customers' electrical energy. Some power plants, such as coal

power plants, diesel power plants, and gas power plants, require fuels purchased from coal trading, HSD trading, and LNG trading. Other power plants, such as wind, solar, and hydropower plants, do not require fuels. All of the power plants produce electricity (ELECTRICITY01) that is transferred to the consumer (ELECTRICITY02) via transmission technology (TRANS). Moreover, during the interconnection scenario, INTER technology transfers electrical energy from the East Nusa Tenggara system to the Java-Bali system. In this model, the fuel cost parameter is included in the technology used to supply the fuel. In addition, the capital cost and fixed and variable costs are included in the generation technology.

After the reference energy system is constructed, the following step is to set the sub-scenarios. There are three sub-scenarios, i.e., BAU, NRE, and NRE with nuclear as the last option scenario. The differences between the sub-scenarios lie in the assumption used. For example, the BAU scenario uses an assumption that the optimization is conducted based on the economic objective function (equation (1)), energy balance constraint (equation (2)), and reserve margin constraint (equation (3)). On the other hand, the NRE scenario uses the BAU scenario's assumptions plus RE share constraint (equation (4)). In comparison, the NRE with nuclear as the last option scenario uses the NRE scenario's assumptions and assumes that nuclear energy is only used when the RE is depleted.

Based on the renewable energy system and the assumptions, the long-term GEP model is constructed. An optimization process is carried out using the model in each scenario to determine the optimum result based on its objective function and constraints. The optimum solution of each scenario compares to each other to find the optimum scenario to achieve the RE targets. Based on the results, power plant capacity, electricity production composition, RE share in the energy mix, LCOE, and CO₂ emission from each scenario can all be determined.

4. CASE STUDY

This research uses the Java-Bali system as the case study to demonstrate the proposed long-term GEP model's performance. The Java-Bali system has a total generating capacity of 34.6 GW, produced predominantly by coal-fired power plants. The energy

Figure 5: Research flowchart

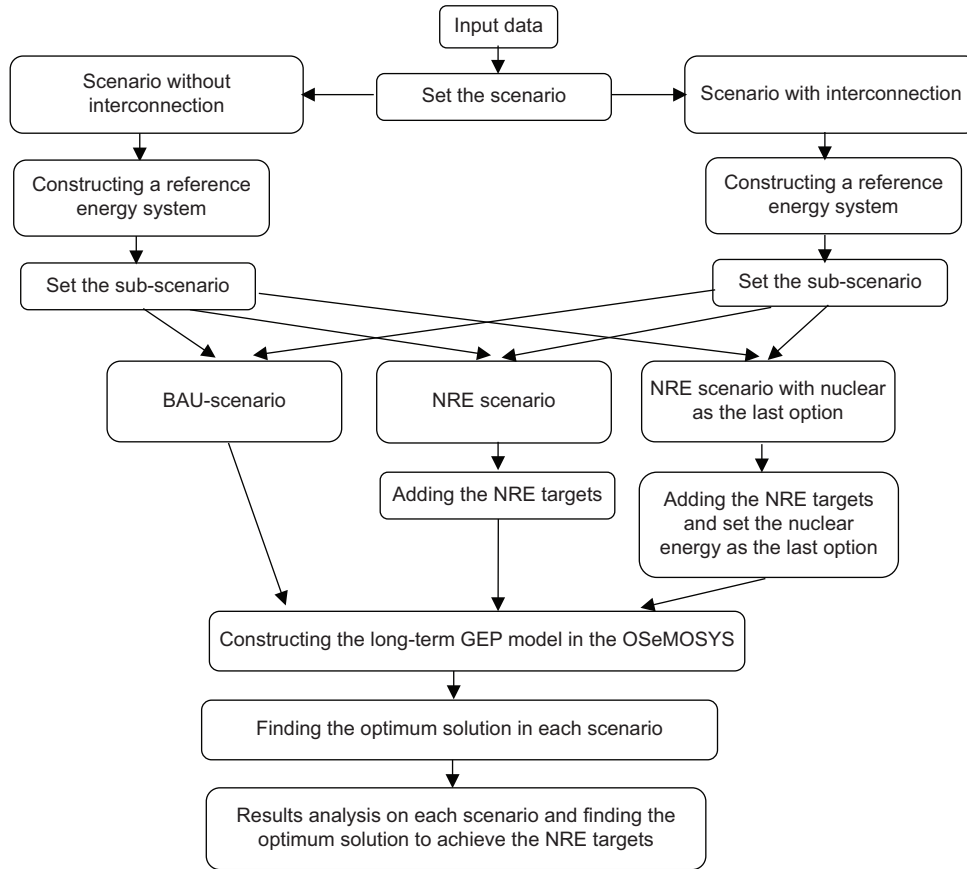
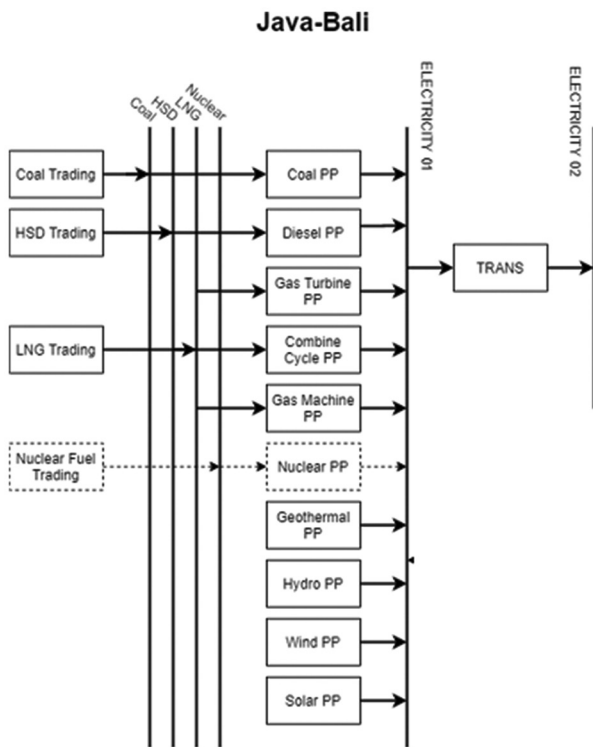

Figure 6: The reference energy system of Java-Bali in the scenario without the interconnection



composition of the power plants in the Java-Bali system is shown in Figure 8.

This study also uses an interconnection option to evacuate the massive RE resources in East Nusa Tenggara to meet the Java-Bali system’s RE target. The East Nusa Tenggara system is one of the power systems located in the eastern part of the Indonesian archipelago. The East Nusa Tenggara electricity system has a total capacity of 285.5 MW. The energy composition in the East Nusa Tenggara system in 2018 is shown in Figure 9.

By considering population, economic, and electrification ratio growth factors, electricity demand has increased in both power systems each year. PT. PLN, as the state-owned utility, has forecasted electric energy and peak load projections from 2020 to 2028. Therefore, this research extrapolates these data to determine 2029–2050 electricity demand and peak load projections. This information is presented in Table 4.

Based on the forecasted demand, it is necessary to implement effective GEP to achieve the optimal energy composition in both systems. An optimization process based on the techno-economic analysis must be conducted to achieve optimal expansion planning. The techno-economic data from the Java-Bali and East Nusa Tenggara systems are shown in Table 5 (NEC, 2017; IESR, 2019; Gielen et al., 2017). The optimization process should also consider the committed power plants as described in Tables 6 and 7 (MoEMR, 2019), as well as fuel cost and local energy resources, as shown in Table 8 (MoEMR, 2019) and Table 9 (MoEMR, 2016). For this process, the current research applied a discount rate value of 10%. The emission factor for each type of power plant is shown in Table 10.

Figure 7: The reference energy system of Java-Bali interconnected with the East Nusa Tenggara power system

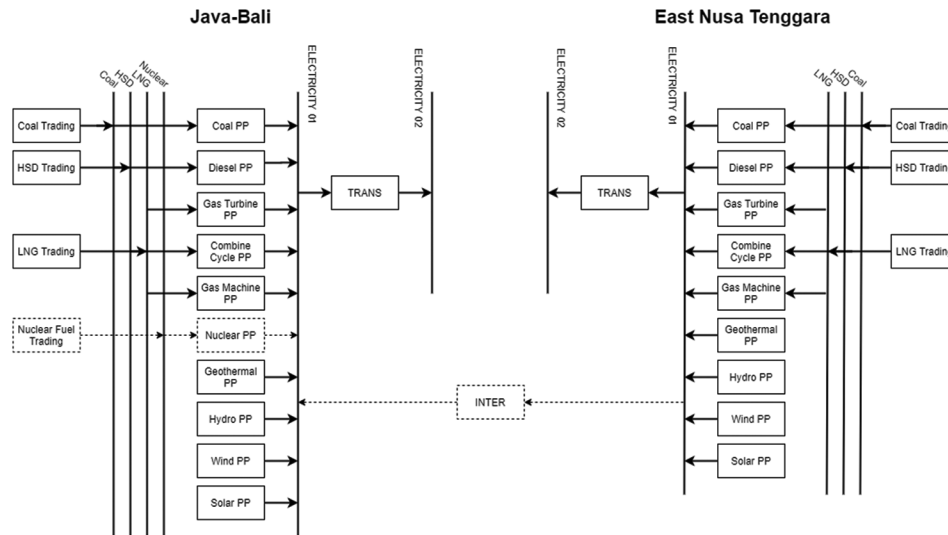

Figure 8: The energy composition of power plants (PPs) in the Java-Bali system (MoEMR, 2019)

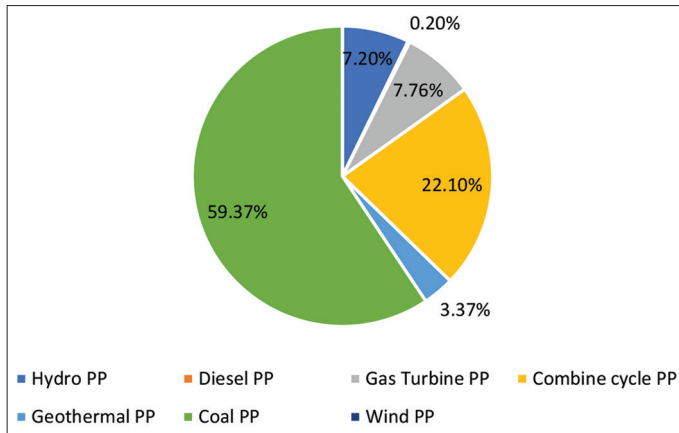

Figure 9: The energy composition of PPs in the East Nusa Tenggara system (MoEMR, 2019)

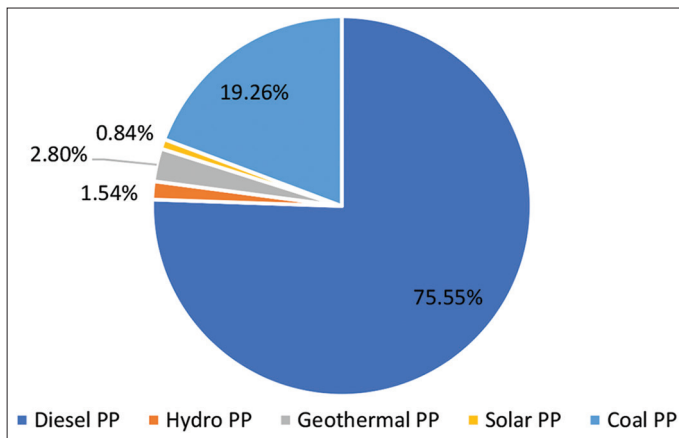

Table 4: Electricity demand and peak load projections – Java-Bali and East Nusa Tenggara Systems, 2029–2050

Year	Java-Bali		East Nusa Tenggara	
	Demand (GWh)	Peak Load (MW)	Demand (GWh)	Peak Load (MW)
2019	177.808	27.557	1.011	213
2020	188.169	29.018	1.104	232
2021	199.423	30.613	1.213	254
2022	211.536	32.368	1.318	266
2023	223.723	34.100	1.426	287
2024	236.557	35.916	1.542	310
2025	250.079	37.823	1.682	338
2026	264.667	39.881	1.833	368
2027	280.256	42.071	1.983	397
2028	296.774	44.391	2.142	429
2029	313.187	46.696	2.299	460
2030	329.602	49.016	2.457	492
2031	346.017	51.335	2.615	523
2032	362.432	53.654	2.772	555
2033	378.847	55.972	2.924	585
2034	395.262	58.291	3.079	616
2035	411.499	60.580	3.235	647
2036	427.897	62.891	3.391	678
2037	444.302	65.206	3.547	709
2038	460.690	67.519	3.703	740
2039	477.074	69.831	3.859	771
2040	493.453	72.143	4.014	802
2041	509.819	74.454	4.169	833
2042	526.176	76.761	4.325	864
2043	542.559	79.072	4.481	895
2044	558.933	81.382	4.636	926
2045	575.308	83.694	4.792	957
2046	591.685	86.005	4.948	988
2047	608.059	88.316	5.103	1.019
2048	624.430	90.626	5.259	1.050
2049	640.802	92.936	5.414	1.081
2050	657.176	95.247	5.570	1.112

5. RESULTS AND DISCUSSION

Based on the optimization process, each power plant’s optimal capacity and energy production in the Java-Bali system in each scenario can be determined. The optimal capacity of the power

plants in all scenarios is shown in Figure 10. It can be seen that until 2024, the capacity of power plants in all scenarios are always similar. This similarity is because the addition of committed power plants is sufficient to meet the demand, and the NRE target is not implemented yet. The NRE target is enforced starting from 2025. Therefore, the

Table 5: Techno-economic parameters (NEC, 2017; IESR, 2019; Gielen et al., 2017)

Power plant	Investment Cost	Fixed O&M Cost	Var. O&M Cost	Capacity Factor	Technical Life
	\$/kWe	\$/kWe/year	\$/MWh	%	years
Diesel PP	600	18	2	25	25
Coal PP	1400	31.3	2	75	30
Gas Turbine PP	700	18	1	35	25
Combine Cycle PP	850	19.2	1	60	25
Machine Gas PP	800	18	1	55	25
Nuclear PP	5500	138	2	80	40
Geothermal PP	4000	30	1	80	30
Hydro PP	2000	6.6	1	56	50
Wind PP	2200	39.55	0.8	30	27
Solar PP	2500	24.7	0.4	19	25

Table 6: Committed PPs in the Java-Bali System (MoEMR, 2019)

COD	Power Plant	Capacity (MW)
2020	Hydro PP	188.6
	Combine Cycle PP	1779
	Geothermal PP	10
	Coal PP	4827
2021	Hydro PP	33.7
	Geothermal PP	10
	Coal PP	1000
2022	Combine Cycle PP	800
	Hydro PP	11
	Geothermal PP	285
	Coal PP	924
2023	Combine Cycle PP	880
	Hydro PP	7.1
	Geothermal PP	385
2024	Coal PP	1000
	Geothermal PP	115
	Coal PP	1660
2025	Geothermal PP	315
	Coal PP	660

Table 7: Committed PPs in the East Nusa Tenggara System (MoEMR, 2019)

COD	Power Plant	Capacity (MW)
2020	Machine Gas PP	25
	Geothermal PP	5
2021	Machine Gas PP	5
	Coal PP	6
2022	Machine Gas PP	50
	Geothermal PP	5
	Coal PP	56
2023	Geothermal PP	5
2024	Coal PP	50
2025	Geothermal PP	5
	Coal PP	24

Table 8: Primary Energy Price (MoEMR, 2019)

Type of primary energy	Price	
Coal	65	\$/Ton
LNG	15	\$/MMBTU
HSD	0.5	\$/Litre
Geothermal	1141.89	Rp/kWh
Nuclear (U3O8)	60	USD/kg

Table 9: Local resources of Java-Bali and East Nusa Tenggara systems (MoEMR, 2016)

Resources	Jawa-Bali (GW)	East Nusa Tenggara (GW)
Geothermal PP	6.18	0.46
Hydro PP	5.68	0.43
Solar PP	3.31	0.73
Wind PP	2.4	1.02

Table 10: CO₂ emission factor (Budi et al., 2011)

Power Plant (PP)	CO ₂ Emission Factor (Ton/MWh)
Coal PP	1.14
Gas PP	1.002
Combine Cycle PP	0.505
Diesel PP	0.786
Geothermal PP	0.2

Table 11. The HVDC line and nuclear power plant operation year

Scenario	Building nuclear power plants	Building HVDC line
1.1 BAU scenario	2035	
2.1 Interconnection BAU scenario	2035	No
1.2 NRE scenario	2028	-
2.2 Interconnection NRE scenario	2028	No
1.3 NRE with nuclear as the last option scenario	2030	-
2.3 Interconnection NRE with nuclear as the last option scenario	2031	2030

have similar capacities. It means that the interconnection between Java-Bali and East Nusa Tenggara power system is not built because of its economics. Scenario 1.2 (NRE) and Scenario 2.2 (Interconnection NRE) give similar capacity results. It means that the interconnection option is still not selected, even when the NRE targets are implemented because building nuclear power plants in Java is more economical to achieve NRE targets than building the HVDC line.

While Scenario 1.3 (NRE nuclear last option) and Scenario 2.3 (interconnection NRE nuclear last option) give similar capacity until 2030, Scenario 2.3 gives a slightly higher capacity than Scenario 1.3 after 2030. In the planning period before 2030, the available RE resources in the Java-Bali power system are enough to

changes in capacity in each scenario begin after 2025. It can be seen that Scenario 1.1 (BAU) and Scenario 2.1 (Interconnection BAU)

fulfil the RE targets until 2030. After the RE resources are depleted, evacuation of the RE resources from the East Nusa Tenggara system is an option to meet the Java-Bali’s RE target. In this scenario, nuclear power plants assume that cannot be an option before all RE resources in the Java-Bali and the Nusa Tenggara system has been utilized. Unfortunately, because the Nusa Tenggara system’s RE resources can only fulfil the Java-Bali system’s RE targets in 1 year, the nuclear power plant requires building in the Java-Bali system in

2031. It shows that the nuclear power plant is necessary to achieve the NRE targets and becomes “the last option”. The last option means that achieving Java-Bali’s NRE target requires nuclear energy in all NRE scenarios. The detailed results on building the nuclear power plant and HVDC line is shown in Table 11.

Table 11 shows that the HVDC line is only built in Scenario 2.3 when the nuclear power plant is set as the last option. The HVDC

Figure 10: The capacity of power plants in each scenario

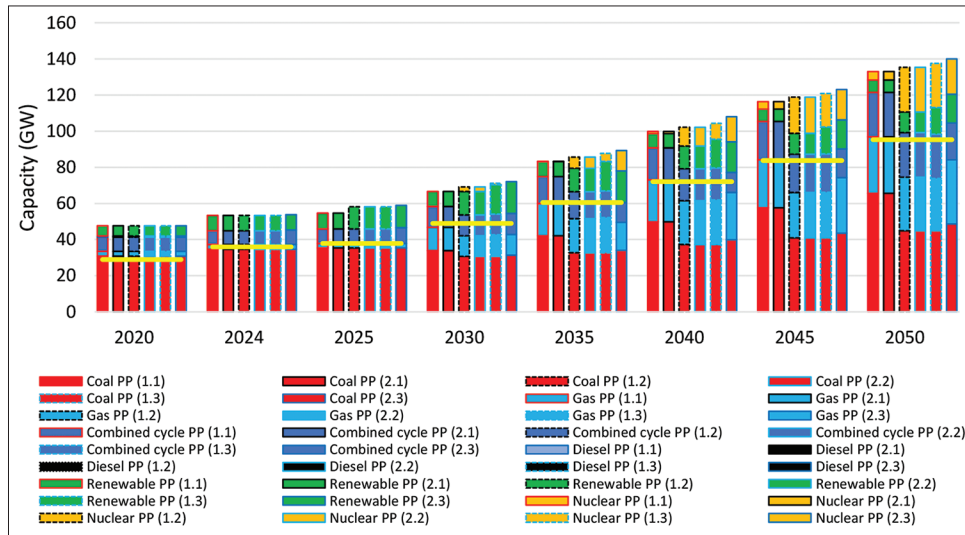

Figure 11: The energy production of power plants in each scenario

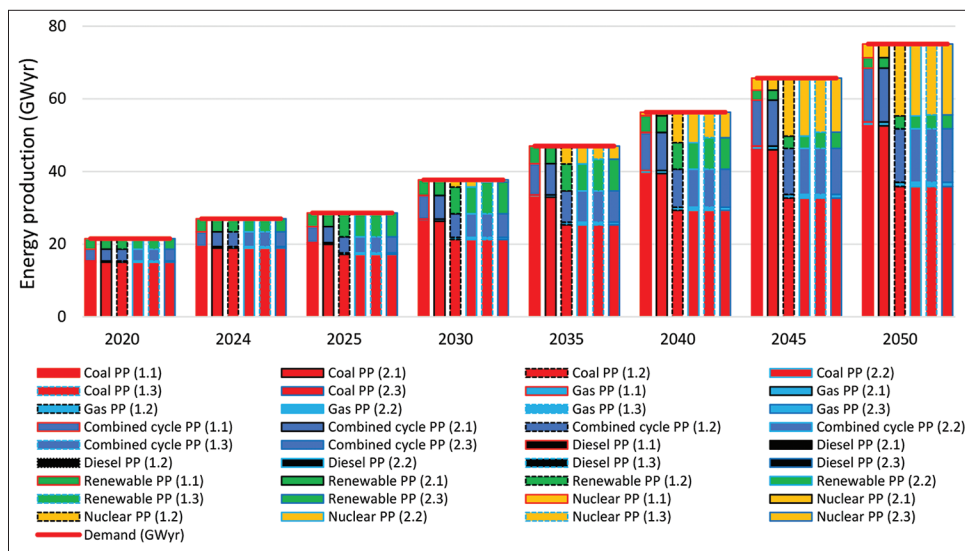
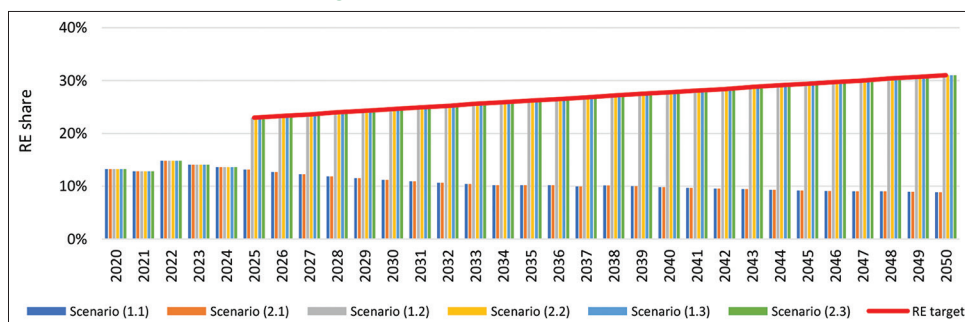

Figure 12: RE share in each scenario



line must be built because of the need to meet the NRE targets and does not depend on the economic factor. Therefore, building the HVD line results in higher costs. However, the nuclear power plant is built in all scenarios, even in the BAU scenario which only considers the economic objective function. This shows that it is economical to build the nuclear power plant in the Java-Bali system without implementing the NRE targets. Implementing the NRE targets causes the operation time of the nuclear power plant to move forward.

The energy production of each power plant in each scenario is shown in Figure 11. All scenarios have a similar energy mix until 2024. Scenario 1.1 and Scenario 2.1 have equal energy mix from 2020 to 2050, which means that the interconnection between Java-Bali and East Nusa Tenggara power system is not built. Scenario 1.2 and Scenario 2.2 have similar energy mixed from 2020 to 2050. It means that the interconnection option is still not selected, even when the NRE targets are implemented. Using nuclear power plants to achieve the NRE targets is more economical than transferring it through the HVDC line. Scenario 1.3 and Scenario 2.3 have similar energy mixed. This similarity shows that the RE resources in the East Nusa Tenggara system are insufficient to fulfil the NRE targets for the long term and still depend on nuclear energy.

The share of RE in the energy mix can be obtained from the simulation, as shown in Figure 12. However, the RE share cannot achieve the targets in the BAU scenario, either in the BAU scenario or Interconnection BAU scenario, because the REs are not economically developed compared with fossil-fueled power plants, especially coal power plants. On the other hand,

the RE target is achieved in the other scenarios because the RE target is set as a constraint in the optimization process. However, implementing these RE targets causes the LCOE increases, as shown in Figure 13.

The LCOE in the BAU scenario (Scenario 1.1 and Scenario 2.1) show that the most economic GEP result in the Java-Bali system is 6.38 cents USD/kWh). However, this scenario does not consider the NRE targets. Hence this scenario cannot be considered to achieve the NRE targets. As said before, implementing the targets causes the LCOE to increase. The obtained LCOE supports this finding in the NRE scenarios (Scenario 1.2, Scenario 2.2, Scenario 1.3, and Scenario 2.3). The amount of increase in the LCOE depends on the scenario considered. Utilizing all NRE resources, including nuclear energy (Scenario 1.2), causes an increase of 0.67 cents USD/kWh from the BAU scenario.

Meanwhile, Scenario 1.3, which sets nuclear energy as the last option, causes an increase of 0.76 cents USD/kWh so that the LCOE becomes 7.14 cents USD/kWh. These results also show that delaying the nuclear power plant operation from 2028 to 2030 causes the cost to achieve the NRE targets to increase by 0.09 cents USD/kWh. The HVDC line option and setting the nuclear energy as the last option create an increase of 2.84 cents USD/kWh so that the LCOE becomes 9.22 cents USD/kWh. These LCOE values show that the most economical solution is the NRE scenario. The most unfavourable scenario is the interconnection scenario with nuclear as the last option.

In addition to increasing LCOE, implementing the NRE targets causes the CO₂ emissions reduced. Figure 14 shows the CO₂ emission in each scenario. The coal power plant is the most significant CO₂ emission producer because it has the biggest CO₂ emission factor and uses as a baseload power plant. The emission becomes different start from 2025 when the NRE target is implemented. Figures 15 and 16 shows the total CO₂ emission from 2020 to 2050 and CO₂ emission reduction with the BAU scenario as a baseline. The NRE scenario (Scenario 1.2) produces the highest CO₂ reduction with the least LCOE. Therefore, the NRE scenario (Scenario 1.2) is the optimum solution to achieve the NRE targets in the Java-Bali system.

Figure 13: The LCOE of each GEP results in each scenario

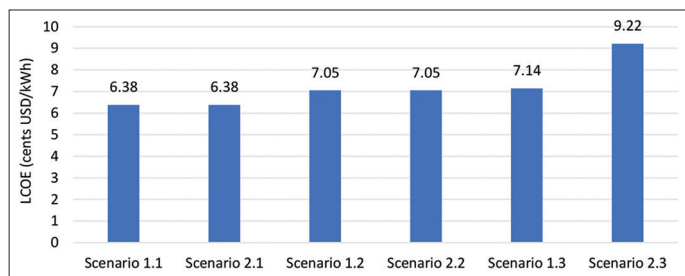

Figure 14: The CO₂ emission in each scenario

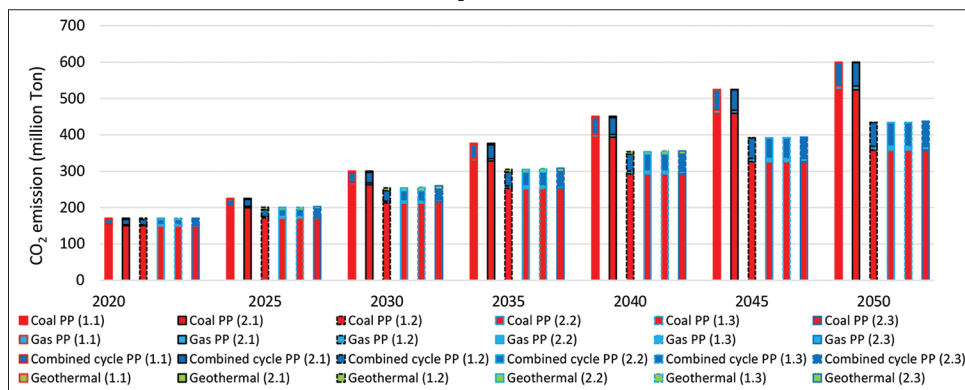

Figure 15: The total CO₂ emission from 2020 to 2050

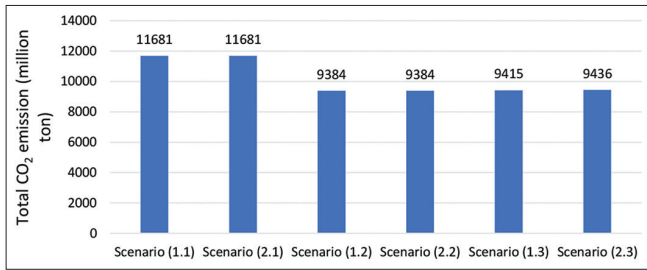

Figure 16: The total emission reduction (using the BAU scenario as a base)

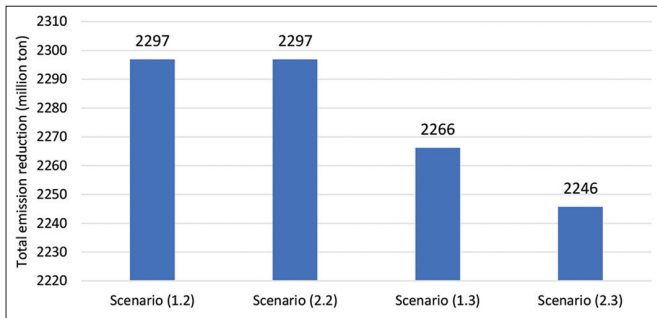

Figure 17: The capacity of NRE power plants in the NRE scenario

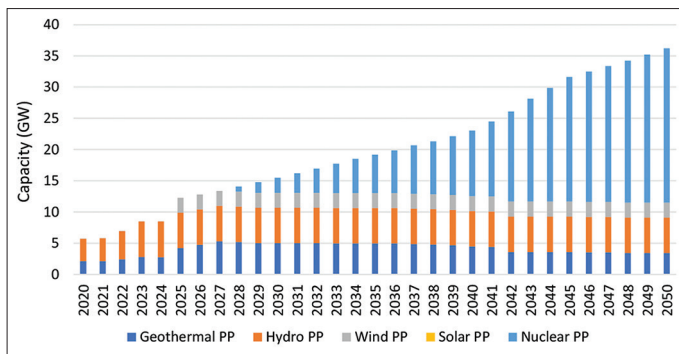
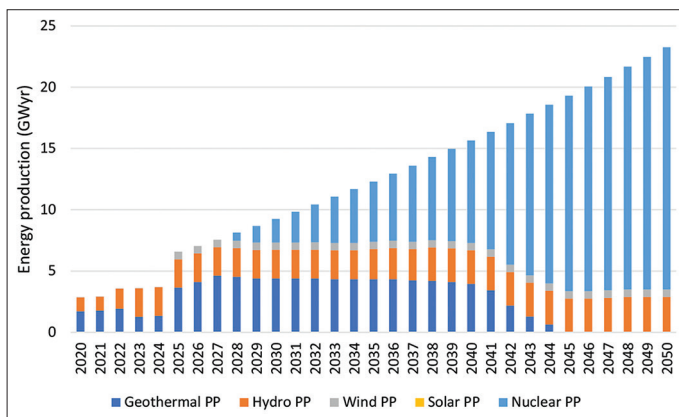

Figure 18: The energy produced by the NRE power plants in the NRE scenario



These research results show that the idea of interconnecting the Java-Bali and East Nusa Tenggara system to achieve the NRE targets is not economically to be developed. The increase of 2.84 cents in the LCOE creates a tremendous additional cost that reduces the utility profit. On the other hand, the concept of interconnecting Java-Bali and East Nusa Tenggara is probably

worth doing if used to achieve the NRE targets and support the Indonesian super grid concept. Therefore, the government must reconsider it and conduct a detailed economic analysis on interconnecting those systems.

Based on its LCOE and emission reduction, the NRE scenario is the optimum solution to achieve the NRE targets in the Java-Bali system. Therefore, the GEP results of the NRE scenario can be used as a reference to create the NRE development roadmap. Figures 17 and 18 show the capacity and energy produced by the NREs powerplant that can be used to develop the roadmap. Thus, the nuclear power plant becomes the backbone to achieve the NRE targets. Unfortunately, the nuclear energy policy of Indonesia is still in the grey area. Therefore, if nuclear energy will be used in 2028, the government must take real action to press the nuclear energy policy button.

Based on its capacity and energy production, geothermal power plant does not grow optimally. Indonesia is located in the ring of fire, but the geothermal power plant is not chosen in the optimization process. It is because its fuel cost is too expensive. The power plant owner should pay the hot steam used as fuel to the other company that owns the geothermal zone at a high price. The location of the geothermal sources is one factor that makes the price is high. Therefore, the government should think of how to reduce the price. In addition, solar energy is auspicious energy in Indonesia because Indonesia is located in an equatorial area. Unfortunately, Java island is a densely populated area that has a problem with land availability. Therefore, the government should consider releasing policies that support rooftop PV investment.

Furthermore, the proposed model can be used for other archipelagic countries by adjusting technology constraints and scenarios based on their problems. This research’s limitations are that this research only considers energy resources that have proven technology, only uses the potency of the energy resources that are technically and economically feasible to be developed and uses Scandinavian HVDC cost as a reference.

6. CONCLUSION

The long-term GEP model of the Java-Bali system is successfully constructed using several scenarios: BAU, NRE, NRE with nuclear as the last option, Interconnection BAU, Interconnection NRE, and Interconnection NRE with nuclear as the last option. Each of these scenarios represents the alternative solution to achieve the NRE targets. The NRE scenario is the optimum solution to achieve the NRE targets in the Java-Bali system. This scenario produces the least LCOE (7.05 cents USD/kWh) and the highest CO₂ emission reduction (2,297 million tons CO₂). In contrast, using an HVDC line to achieve the NRE target is the most unfavourable solution because it produces the highest LCOE (9.22 cents USD/kWh) and the least CO₂ emission reduction (2,246 million ton CO₂). The nuclear power plant is required to achieve the NRE targets and becomes “the last option”. The last option means that achieving Java-Bali’s NRE target requires nuclear energy in all NRE scenarios.

With these research results, stakeholders can determine policies related to nuclear power plants, geothermal power plants, and rooftop PVs in the Java-Bali system. Other factors beyond economics must also be considered if the government wishes to build an HVDC interconnection line from the East Nusa Tenggara system to the Java-Bali system, e.g., reliability improvement, Indonesia's super grid, and an HVDC pilot project.

7. ACKNOWLEDGMENT

The authors would like to thank Program Penelitian Dasar Perguruan Tinggi (PDUPT), Deputy Bidang Penguatan Riset dan Pengembangan, Kementerian Riset dan Teknologi/Badan Inovasi Nasional for the support.

REFERENCES

- ABB. (2015), ABB Wins \$900 Million Order to Connect Norwegian and German Power Grids. Available from: <https://www.new.abb.com/news/detail/13196/abb-wins-900-million-order-to-connect-norwegian-and-german-power-grids> [Last accessed on 2020 Nov 27].
- ABB. (2017), HVDC Light It's Time to Connect. ABB. Available from: <http://www.new.abb.com/docs/default-source/ewea-doc/hvdc-light.pdf?sfvrsn=2>
- Asplund, G., Lindén, K., Marzin, A., Barker, C. (2013), HVDC grid feasibility study.
- Bagheri, M., Shirzadi, N., Bazdar, E., Kennedy, C.A. (2018) Optimal planning of hybrid renewable energy infrastructure for urban sustainability : Green Vancouver. *Renewable and Sustainable Energy Reviews*, 95, 254-264.
- Bersalli, G., Menanteau, P., El-Methni, J. (2020), Renewable energy policy effectiveness : A panel data analysis across Europe and Latin America. *Renewable and Sustainable Energy Reviews*, 133, 1-11.
- Budi, R.F.S., Sarjiya, S., Hadi, S.P. (2017), Potential method for optimization of power plant expansion planning in Jawa-Madura-Bali electricity system. *Communications in Science and Technology*, 2, 41.
- Budi, R.F.S., Sarjiya, S., Hadi, S.P. (2019), Review on generation expansion planning based on Indonesia as an archipelagic country. In: 2019 5th International Conference on Science and Technology (ICST). Yogyakarta, Indonesia: IEEE. p1-6.
- Budi, R.F.S., Sarjiya, S., Hadi, S.P. (2020a), A Comprehensive Review on Uncertainty of Renewable Energy and its Prospect to Fulfil Indonesia's Renewable Target. Vol. 2255. United States: AIP Conference Proceedings. p1-6.
- Budi, R.F.S., Sarjiya, S., Hadi, S.P. (2020b), A critical review of generation expansion planning based on independent power producer delay problem in Indonesia. In International Conference on Technology an Policy in Electric Power and Energy (ICT-PEP). Bandung, Indonesia: IEEE. p1-6.
- Budi, R.F.S., Suparman, Salimy, D.H. (2011), The analysis of CO₂ emission at the study of electricity generation development planning with nuclear option for Bangka Belitung (analisis emisi CO₂ pada studi perencanaan pengembangan pembangkitan listrik wilayah Bangka Belitung dengan opsi nuklir). *Jurnal Pengembangan Energi Nuklir*, 13(1), 44-55.
- Budi, R.F.S., Suparman. (2011), Generation System Expansion Planning Study of Bangka Belitung With Nuclear Option (Studi Perencanaan Pengembangan Pembangkit Wilayah Bangka Belitung dengan Opsi Nuklir). Pangkal Pinang: Prosiding Seminar Nasional Pengembangan Energi Nuklir IV. p267-277.
- Budi, R.F.S., Widodo, W.L. (2015), Sensitivity analysis of nuclear power plant investment cost in West Kalimantan's electricity planning (analisis sensitivitas biaya investasi PLTN dalam perencanaan kelistrikan Kalimantan barat). In *Prosiding Seminar Nasional Teknologi Energi Nuklir*. Vienna, Austria: IAEA. p1-9.
- Elia, A., Kamideliwand, M., Rogan, F. (2020), Impacts of innovation on renewable energy technology cost reductions. *Renewable and Sustainable Energy Reviews*, 110488, 1-31.
- Elliott, D., Bell, K.R.W., Finney, S.J., Adapa, R., Brozio, C., Yu, J., Hussain, K. (2016), A comparison of AC and HVDC options for the connection of offshore wind generation in Great Britain. *IEEE Transactions on Power Delivery*, 31(2), 798-809.
- Gardumi, F., Shivakumar, A., Morrison, R., Taliotis, C., Broad, O., Beltramo, A., Alfstad, T. (2018), From the development of an open-source energy modelling tool to its application and the creation of communities of practice: The example of OSeMOSYS. *Energy Strategy Reviews*, 20, 209-228.
- Gielen, D., Saygin, D., Rieger, J. (2017), *Renewable Energy Prospects: Indonesia, a REMAP Analysis*. United Arab Emirates: International Renewable Energy Agency.
- Google Map. (2020), Google maps-Indonesia. Available from: <https://www.google.com/maps/place/روشدور+هاگتسي/@35.4432459,50.9030998,17z/data=!3m1!4b1!4m5!3m4!1s0x3f92764c184dce51:0xe842e7bce7a61770!8m2!3d35.4432549!4d50.9008577?hl=FA> [Last accessed on 2020 Feb 21].
- Härtel, P., Vrana, T.K., Hennig, T., von Bonin, M., Wiggelinkhuizen, E.J., Nieuwenhout, F.D.J. (2017) Review of investment model cost parameters for VSC HVDC transmission infrastructure. *Electric Power Systems Research*, 151, 419-431.
- Howells, M., Rogner, H., Strachan, N., Heaps, C., Huntington, H., Kypreos, S., Roehrl, A. (2011a), OSeMOSYS: The open source energy modeling system. An introduction to its ethos, structure and development. *Energy Policy*, 39(10), 5850-5870.
- Howells, M., Rogner, H., Strachan, N., Heaps, C., Huntington, H., Kypreos, S., Roehrl, A. (2011b), OSeMOSYS: The open source energy modeling system. *Energy Policy*, 39(10), 5850-5870.
- IESR. (2019), *A Roadmap for Indonesia's Power Sector: How Renewable Energy Can Power Java-Bali and Sumatera*. Indonesia: IESR. p64.
- Jovcic, D., Ahmed, K. (2015), *High Voltage Direct Current Transmission : Converters, Systems, and DC Grids*. 1st ed. United Kingdom: Wiley.
- Khalil, M., Berawi, M.A., Heryanto, R., Rizalie, A. (2019), Waste to energy technology: The potential of sustainable biogas production from animal waste in Indonesia. *Renewable and Sustainable Energy Reviews*, 105, 323-331.
- Lawrence, A. (2020), Energy decentralization in South Africa: Why past failure points to future success. *Renewable and Sustainable Energy Reviews*, 120, 109659.
- Mai, T., Hand, M.M., Baldwin, S.F., Wiser, R.H., Brinkman, G.L., Denholm, P., Bazilian, M. (2014), *Renewable electricity futures for the United States*. IEEE Transactions on Sustainable Energy, 5(2), 372-378.
- McPherson, M., Karney, B. (2014), Long-term scenario alternatives and their implications: LEAP model application of Panama's electricity sector. *Energy Policy*, 68, 146-157.
- MoEMR. (2016), *Statistics of New and Renewable Energy and Conservation Energy*. Indonesia: MoEMR.
- MoEMR. (2019), *Electricity Supply Business Plan PT. PLN (Persero) 2019-2028*. Jakarta: MoEMR.
- Musa, S.D., Zhonghua, T., Ibrahim, A.O., Habib, M. (2018), China's energy status: A critical look at fossils and renewable options. *Renewable and Sustainable Energy Reviews*, 81, 2281-2290.
- National Energy Council. (2016), *Indonesia Energy Outlook 2016*. Beijing: National Energy Council. p139.

- National Energy Council. (2017), National Energy General Plan. Jakarta: National Energy Council.
- National Energy Council. (2020), National Energy Mix. Jakarta: National Energy Council.
- NEC. (2017), Technology Data for the Indonesian Power Sector-Catalogue for Generation and Storage of Electricity. Japan: NEC. p1-140.
- Pérez-Denicia, E., Fernández-Luqueño, F., Vilariño-Ayala, D., Manuel Montaña-Zetina, L., Maldonado-López, L.A. (2017), Renewable energy sources for electricity generation in Mexico: A review. *Renewable and Sustainable Energy Reviews*, 78, 597-613.
- Presiden Republik Indonesia. (2014), Indonesian Government Law No 79 In 2014 About National Energy Policy. Indonesia: Presiden Republik Indonesia.
- REN. (2019), Renewables 2019 Global Status Report. Rajasthan: REN.
- Saini, V., Gupta, R.P., Arora, M.K. (2016), Environmental impact studies in coalfields in India: A case study from Jharia coal-field. *Renewable and Sustainable Energy Reviews*, 53, 1222-1239.
- Sarjiya, Budi, R.F.S., Putranto, L.M. (2020a), Achieving new and renewable energy target : A case study of Java-Bali power system, Indonesia. In: 2020 2nd International Conference on Smart Power and Internet Energy Systems. Bangkok, Thailand: IEEE. p1-6.
- Sarjiya, Budi, R.F.S., Putranto, L.M. (2020b), Achieving new and renewable energy target : A case study of java-bali power system, Indonesia. In: 2020 2nd International Conference on Smart Power and Internet Energy Systems. Bangkok, Thailand: IEEE. p1-6.
- Sen, R., Bhattacharyya, S.C. (2014), Off-grid electricity generation with renewable energy technologies in India: An application of HOMER. *Renewable Energy*, 62, 388-398.
- Tsai, M.S., Chang, S.L. (2015), Taiwan's 2050 low carbon development roadmap: An evaluation with the MARKAL model. *Renewable and Sustainable Energy Reviews*, 49, 178-191.
- Van Eeckhout, B., Van Hertem, D., Reza, M., Srivastava, K., Belmans, R. (2010), Economic comparison of VSC HVDC and HVAC as transmission system for a 300MW offshore wind farm. *European Transactions on Electrical Power*, 20, 661-671.
- Vemaps. (2020), Grey Map of Indonesia with Provinces-free Vector Maps. Available from: <https://www.vemaps.com/indonesia/id-04> [Last accessed on 2020 Feb 20].
- Welsch, M., Deane, P., Howells, M., Gallachóir, B.O., Rogan, F., Bazilian, M., Rogner, H.H. (2014), Incorporating flexibility requirements into long-term energy system models-A case study on high levels of renewable electricity penetration in Ireland. *Applied Energy*, 135, 600-615.
- Yang, W., Pestana, R., Zhang, X., Esteves, J., Li, Y., Reis, F. (2019), The current status and experience of renewable energy development in Portugal. In: 2019 Chinese Control and Decision Conference (CCDC). United States: IEEE. p5090-4.
- Zhao, P., Lu, Z., Fang, J., Reddy, S., Jiang, K. (2020), Determinants of renewable and non-renewable energy demand in China. *Structural Change and Economic Dynamics*, 54, 202-209.